

Technical Article

## Emergency stop switches. *Use, properties and selection.*

Often discussed, often misunderstood: with emergency stop switches, the right choice can be critical in terms of human safety, the protection of machinery, and potential downstream costs. While directives and industrial standards are critical

for establishing norms for market compliance, they are not always absolutely clear and often misunderstood. There is a need for years of expertise – what do you need to consider?

When do you need emergency stop switches? What do they need to be able to do? Such ostensibly simple questions can

tie even specialists up in knots. In fact, it's often not even clear what an emergency stop switch actually is in the first place. Ambiguous terminology, unclear standards and incorrect technical content only further exacerbate the confusion. Online research can be inconclusive – and sometimes results in entirely unresolvable contradictions. Well, it's time to clear things up!

# Only emergency stop switches are mandatory.

*The mandated emergency stop switch stops a machine in an emergency and is subject to strict regulations and numerous standards. To make the right choice, it is advisable to study these devices in more depth.*

The right choice of product is important. An emergency stop switch's design is an essential part of compliance with many industry standards and regulations. The purpose of an emergency stop switch is to reliably protect people from injury and machinery from damage. So just to clear up the most important detail – any sold or operated machine must always be fitted with an emergency stop switch. We're not talking about coffee machines, washing machines, or hand-held devices such as drills. This requirement is directly related to machinery governed by the European Union's Machinery Directive.

All manufacturers are required to declare explicitly in writing that their machinery is compliant with this directive, which is why "conformity assessment procedures" are required to allow for the device to carry a CE mark. The member states apply penalties for violations of the directive. This is why it is important to know what defines emergency stop switches and which "related" pushbuttons do not satisfy the requirements – but which are commonly confused with them (see table 1).

German term	English term	Function
NOT-HALT Taste	Emergency stop switch	Stop in an emergency
NOT-AUS Taste	Emergency off switch	Switch off in an emergency
Stopp Taste	Stop switch	Often: on/off

Table 1: Emergency stop switches and their "relatives".

## Key directives and standards

The European Union's Machinery Directive quotes "emergency stop functions" as a safety measure to safeguard against human error or technical failure. The Machinery Directive therefore mandates the use of emergency stop actuators. It defines how these are to be designed, built and positioned. It describes how these devices are operated in an emergency, how they work, and how they interact with the machine control system. It also establishes that emergency stop switches must be capable of withstanding rough handling. Various industrial standards go into greater depth regarding these:

- DIN EN ISO 13850 on safety of machinery describes the fundamental requirements of emergency stop functions and the design of the actuators

- Product standard DIN EN 60947 for low-voltage switchgear and control gear devices describes the key electromechanical features and test methods for emergency stop devices within section EN 60947-5-5
- DIN EN 60204 addresses the electrical equipment of machinery and defines the "stop categories"

These three standards define the colour code system of components, their labelling and allowable symbols. They lay out standards regarding form, fixture and location. They also stipulate how they work and the electromechanical aspects such as locking mechanisms, reset mechanisms, positive opening action of contact elements and lighting. Details on these design features are provided in the article.

# Stop switches – easy to use, but a complex process.

*“What does the Machinery Directive mean by ‘stop’?”*

What does the Machinery Directive mean by “stop”? Emergency stop switches prevent unpredictable, hazardous situations by quickly stopping movements or processes – basically stopping a machine’s action without cutting its power supply. Emergency stop switches are operated if parts get jammed in a production line or if an operator is in a hazardous situation. In such situations, a person – be it a specialist or a layman – must be able to easily and intuitively stop the machine with one simple action.

Once an emergency stop switch has been actuated, it must not be possible to prevent this stop process from occurring in any way. An emergency stop switch must lock into place, and the stoppage must continue until clearance to be reset is deliberately given. Even when clearance is given, the machine cannot simply carry on working. Clearance is simply permission for the machine to be brought back into operation.

The machine should not cause any further hazards during an emergency stop as it is in a non-functional state. For it to return to its normal operational state, it may mean that the machine has to immediately execute a special sequence of safety movements which would not be possible if the power were cut. For example, cutting the power on a press may have disastrous consequences in a hazardous situation – pistons might collapse which can cause actions that could crush limbs. Another example can involve devices that utilise suction. Without power, uncontrolled drops of heavy loads can cause significant damage to products, equipment and, more importantly, operators of that machinery.

With emergency stop switches, it is of extreme importance that they never fail – even in the event of a fault in the control system or in their

logic and regardless of the mode of operation. So, as we see, behind what appears to be simply a press of a button, there is actually a very refined electrical mechanism. Various industrial standards describe the finer details thereof. DIN 13850 equates the stopping of a machine with the emergency stop function.

## **Emergency off – similar name, different function**

Emergency off switches on the other hand are not bound by any laws. They are only required in special circumstances. Emergency off switches shut off the electrical power supply, or, more precisely, ensure that the power supply is galvanically isolated. They function differently when compared to emergency stop switches and certainly have a different purpose. For example, they are fitted in electrical facilities where laypeople should not even be in the first place. But even specialists can accidentally come into contact with electrically live components, causing their muscles to contract in a way such that they are unable to free themselves. This is where the emergency off switch comes into play. Only cutting the power can save a person who has been exposed to electric shock. The described scenario illustrates how rarely emergency off switches are needed – provided that they are used correctly. An emergency off button is also useful where there are risks of occurrences such as cable fires. Unfortunately, there are cases where emergency off switches are installed where emergency stop switches should be. This is dangerous. Emergency off switches do not have the exact internal technology or functions of an emergency stop switch. For emergency off switches, there are at the very least no dedicated product standards.

# Stop switches – the third option.

And to add to the confusion, there is also the choice of a stop switch. Like emergency off switches, they do not need to satisfy the aforementioned standards and highest level of distinction of emergency stop switches. This is why their design is, and can be, less sophisticated. This affects, for example, the locking mechanism or the reset functionality. Positive opening contacts are also not mandatory with stop switches. As a result, snap-action switching elements can be used instead of the slow-make forced opening switching elements of emergency stop switches. Stop switches often function as on/off switches. So, there are also no fixed rules about the colour of such lenses. For example, some might be red and others can be green.

## Unhelpful jargon

Unfortunately, the key directives and standards have themselves only helped to increase confusion and misinterpretation in the past. The predecessor of the Machinery Directive was not clear sometimes simply due to improper translation. This unfortunately is still the case with DIN EN 60974 5-5, the title of which was translated from the German term “NOT-AUS” which means “emergency off”, even though “emergency stop” was meant. There are also other standards that make reference to “emergency off” control elements or “emergency off” switches, but they are actually referring to “emergency stop” mechanisms. And of course, people often refer to many red “buttons” simply

as “emergency stop” buttons even though they are referencing “emergency off” buttons due to a misunderstanding of function.

Even if some new directives and standards have since corrected the improper use of terminology, it is always important to ask what is really meant. Make sure to get specific clarification in order to avoid these misconceptions.

## Mounting, construction and terminals

Ideally, emergency stop switches should be mounted in a way that prevents them from being accidentally actuated or pressed. Protective shrouds help to achieve this safeguard. At the same time, emergency stop switches must be easily visible and accessible – from any control point and without exposing the user to risk. DIN EN ISO 13850 and DIN 60204-1 provide aid in determining the number needed, their location, how far apart, and how high emergency stop switches should be.

Emergency stop switches are usually available – depending on their construction or purpose – with industry standard mounting cut-outs measuring 16.2 or 22.3 mm in diameter. The purpose usually dictates their construction – there are modular styles or compact emergency stop switches options. Modular ones are generally used. These comprised of multiple components that consists of an actuator or mechanical element and contact block(s) or the switching element(s). Mono-block switches (see figure 1) tend to be more compact and are therefore suitable in situations where space is limited – like on remote controls. Emergency stop switches are available with a variety of terminal types to allow them to be connected to machine controllers. Depending on where in the world they are to be used and what they will be used for, soldered, plug-in, cable, screw and push-in terminal types may be needed.

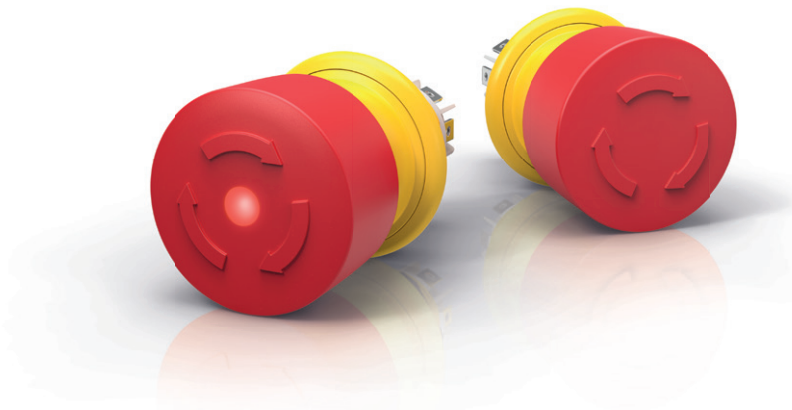

Figure 1: Series 61 E-Stop compact – A compact EAO mono-block switch with integrated switching element, twist-to-release mechanism and with/without illumination.

# Safety under normal operating conditions.

Emergency stop switches often need to satisfy special requirements not only in emergencies, but also under the normal operating conditions of a machine. This is why high-quality emergency stop switches are designed for different degrees of protection. “IP” protection degrees are made up of two digits: the first refers to the product’s protection against penetration by solid foreign objects, while the second refers to protection against fluid ingress. IP65, IP66, IP67 and IP69K are the protection classes usually requested for emergency stop switches. The first “6” in each case refers to switches that are completely dust-proof. There are the following differences in terms of how they are protected against fluid ingress:

Degree of protection	Significance
IP65	Protection against water jets (from nozzles) from any angle
IP66	Protection against intense water jets
IP67	Protection against brief submersion
IP69K	Protection against water from pressure/steam jet cleaners, specifically for road vehicles (DIN 40050-9)

Table 2: Degree of protection and their meanings.

## Intuitive and robust

Emergency stop devices are easily recognisable with their signature red colour on an easily identifiable yellow background to provide effective contrast. The combination of these two trademark colours should only be used for emergency control elements. The colours use RAL numbers in accordance with DIN 13850. The form and texture of the pushbutton must make it very easy to press with a safe, quick and sometimes powerful strike with the fist, wrist or palm. In particular, the standard recommends the use of

conical forms or “mushroom heads”. It also stipulates a quality standard, namely that the switch must be capable of withstanding at least 6050 operations. DIN EN 60947-5-5 also describes the “swing hammer test” – a defined test method for mechanical stresses.

## Foolproof locking mechanism

When someone presses an emergency stop switch, this is where its locking mechanism comes into play. The two standards DIN EN ISO 13850 and DIN EN 60947-5-5 specify the requirements of the Machinery Directive in greater detail. To paraphrase, it is stated that the button must lock into place when pushed, until it is manually released from that position. This means that the emergency signal must remain constantly on until that time. This is why quality products are designed to be “foolproof” – the signal is always triggered upon a press of the actuator as soon as the red button head locks into place. Conversely, there is never a signal without the button head locking into place. Even the most inventive operator should not be able to find a way to circumvent the system. Not every “red button” meets this requirement.

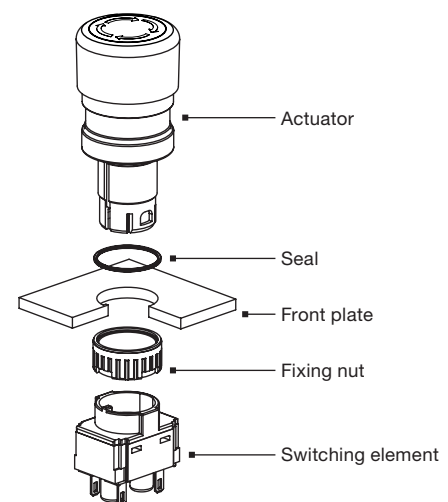

Figure 2: Construction of a modular emergency stop switch.

## Fail-safe positive action.

This means that when the button locks into place, this triggers a mechanism and activates the switching element. This too is required by the product standard DIN EN 60947 – the power circuit must be interrupted by way of positive opening action, as an emergency signal for the machine controller. This is the only way to consistently guarantee safety, because if the emergency signal was triggered by an electrical pulse instead of by its absence, the emergency stop mechanism could fail as a result of a broken cable, for example. The same product standard also requires the mechanical contact isolation to not be dependent on elastic components such as springs. This is essential for ensuring that the contact is isolated as soon as the emergency stop switch is pressed. A defective spring could have dangerous or costly consequences if the mechanism were to fail because of it. This is why emergency stop switches use slow-make/positive opening switching elements and not snap-action (see figure 3). Emergency stop switches must be fail-safe.

### Manual resets for confirming clearance

This means that the emergency stop switch guarantees that when pressed, a hazardous situation has temporarily been prevented – with absolute reliability. To resume operation of the machine, the operator first needs to manually reset the locked emergency stop switch. According to the Machinery Directive, this prior clearance is required. DIN EN ISO 13850 also requires the emergency stop to be triggered and reset from the same button. With larger machines or longer production lines with several buttons, the first question to be asked is “which button needs to be pressed in a chaotic emergency?” This is why there are emergency stop switches which offer illumination. It is activated on any pressed button. The machine operator can now reset it, causing the light to switch off, the electrical contacts to be closed and the machine to be cleared for continued operation.

Series 04 snap-action switching element

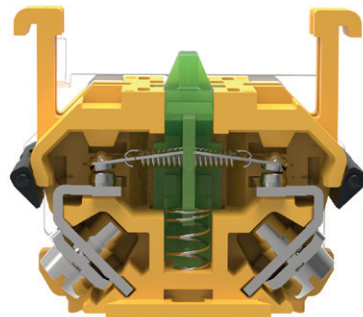

Series 04 slow-make switching element

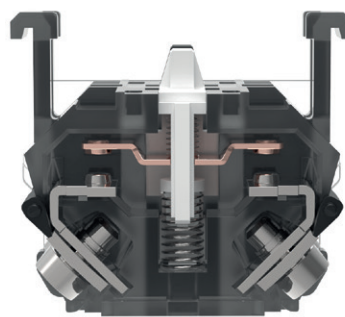

Figure 3: The slow-make switching element (right) isolates the contacts reliably. With snap-action switching elements (left), defective elastic components such as springs can prevent the contacts from being isolated, thus putting the emergency signal at risk.



## Sensible, clear unlocking process.

The standards list a variety of unlocking methods for resetting an emergency stop switch: twist, pull or key. The question of whether twisting or pulling is more suitable is usually a matter of what the space conditions permit; where space is limited, twisting is difficult or sometimes even impossible. Especially with emergency stop switches on remote controls, pull-to-unlock mechanisms are more likely to be used. However, the choice can be a matter of preference.

Emergency stop switches that are unlocked by twisting should ideally feature arrows to indicate in which direction the button needs to be rotated. Various standards address these arrows. It is important for them to be of the same colour as the pushbutton actuator, but also for them to be raised (as shown in figure 1). White arrows were allowable in the past. While the use of old emergency stop switches with white arrows is still

permitted, the arrows are potentially confusing and therefore not recommended. In an emergency – so when the emergency stop needs to be pressed, the arrows should not suggest that the button needs to be turned. This might result in lost time. This is why, since 2016, new machines are required to indicate the direction the button needs to be turned to unlock it using red arrows.

A key mechanism limits unlocking to authorised personnel. However, practice doesn't always live up to theory. A person who is not always on site cannot always be there to unlock. This is why the key is often just left in. This makes emergencies a potentially painful experience if the key is left in the button head to be pressed (see figure 2). In worst-case scenarios, it may even prevent the emergency stop from being triggered. The use of a key locking mechanism in an emergency stop switch should therefore be carefully considered.

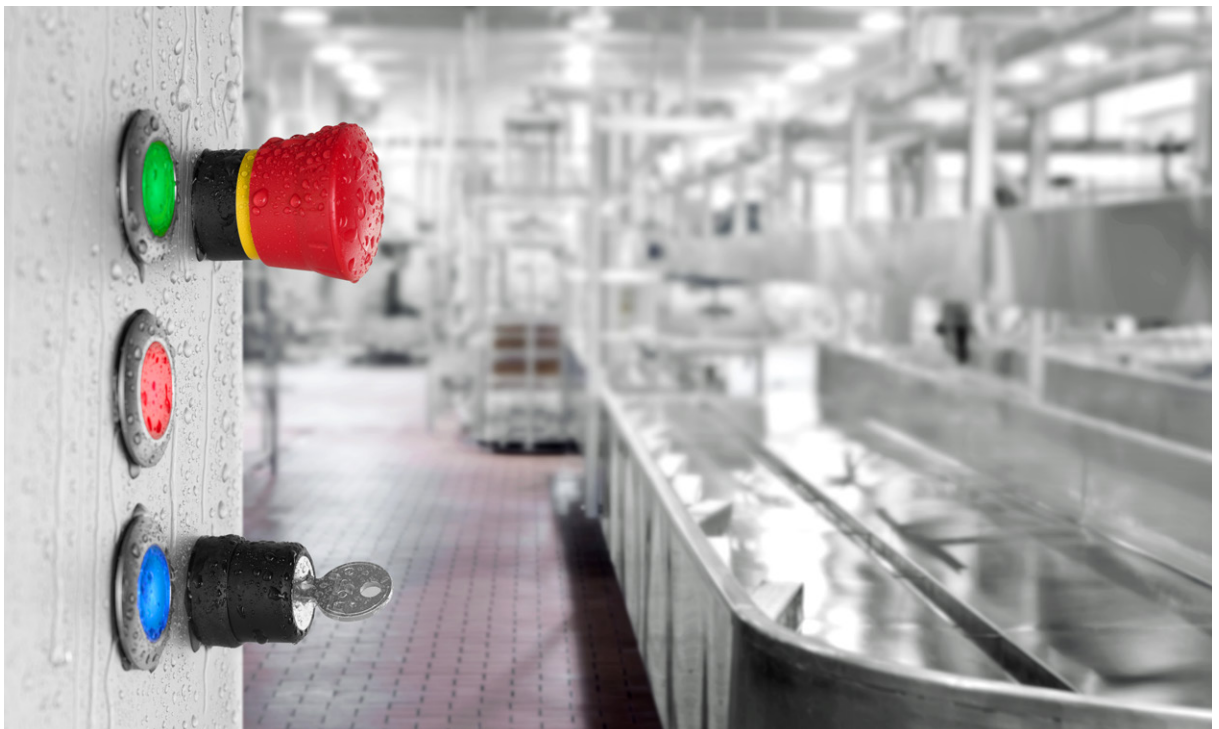

# Involve experts.

## Sources:

EAO; Directive 2006/42/EC of the European Parliament and of the Council of 17 May 2006 on machinery, and amending Directive 95/16/EC; DIN EN 60947: Low-voltage switchgear and controlgear; DIN EN ISO 13850: Safety of machinery – Emergency stop function; DIN EN 60204-1: Safety of machinery. Electrical equipment of machines; VDE article series 154: Emergency stop or emergency off? Gehlen, Rudnik; Wikipedia.

So as we see, not every “red button” is an emergency stop switch. Not every button referred to as an emergency stop switch satisfies the regulatory requirements of the markets. And not every compliant emergency stop switch is equally intuitive and reliably safe – and unfortunately, they are not always correctly employed either. At the end of a shift in production, the machinery should not be stopped using the emergency stop switch. It’s not a “finishing up” button. This is why it is worth studying directives and industrial standards and questioning the terminology. It is also advisable to bring in expert assistance. It is tricky but important to pick the right product – to ensure that a machine is ready for market by providing the proper mode of the safety of users.

With emergency stop switches from EAO, the expert partner for human machine interfaces, design engineers have more than 2000 possible feature combinations to choose from. So our expertise and range allows you to select the optimal product. If you count on quality and safety, if you want to be compliant with international

markets and have standards regarding design, EAO can provide you with the right emergency stop switch – or entire compatible system solutions.

Emergency stop switches are also in a constant state of evolution – both in terms of safety and for specific applications. While many machine buttons have vanished following the adoption of digital applications in recent years, emergency stop switches continue to be a physical button. This is largely due to their function – and the strict safety requirements placed upon them. Even so, at EAO, the engineers still progressively think about topics such as wi-fi controllers, the “internet of things” – a field in which regulations and standards have not yet fully matured. So for the foreseeable future, there is unlikely to be much more clarity provided for choosing emergency stop switches. This makes a partner with expertise all the more important.

EAO headquarters in Olten (Switzerland).  
Errors and changes possible.

## The new EAO E-Stop Switch Configurator. *Intuitive use. Fast delivery time.*

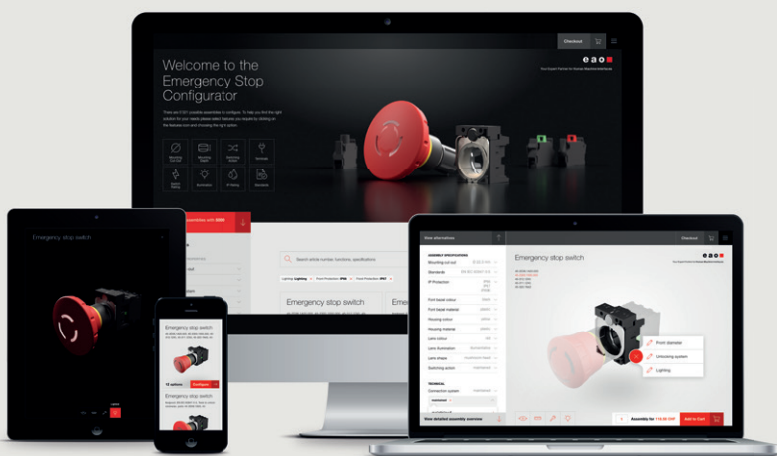

The World of E-Stops – EAO has created an interactive virtual 3D tool in the form of the Emergency Stop Configuration Tool to help engineers and designers intuitively configure modular products to meet their individual requirements. Benefit from the advantages of this unique industry solution and enjoy the premium customer experience:

[direct.eao.com](http://direct.eao.com)

