

Latest Technological Trends for Conductive Polymer Aluminum Solid Electrolytic Capacitors

Digital devices such as computers and game devices for home-use are demonstrating a significantly high level of performance, and are becoming increasingly common in homes. In place of tablet PCs, “smart books” have been seeing favorable sales trends recently, and there are even some who own a multiple number of devices and use them for different purposes. Society and lifestyles are changing at an even more rapid pace than we have expected, and the driving force is the increasing speed and growing functionality of computers. The key to these advancements in speed and functionality, on the other hand, lies in the improvements being made to central processing units (CPUs). The growing speed and functionality of CPUs has in turn led to a demand for power circuits with different characteristics than conventional circuits.

Advancements in the speed and functionality of CPUs mean an accompanying increase in operating frequencies. As a result, a higher response speed is demanded of the capacitors used in the power circuits. In addition, the capacitors need to have outstanding high-frequency features, compact and low equivalent series resistance (ESR), as well as greater stability under high temperatures as they will be installed near the CPU. It would be difficult to meet these requirements with only aluminum electrolytic capacitors that use an electrolytic solution. Consequently, conductive polymer aluminum solid electrolytic capacitors that make use of conductive polymers in place of electrolytic solutions were developed to fulfill the above requirements.

Currently, these new capacitors are not only used in computers, but are also used to smooth power circuits and in current rejection. There are an increasing number of applications for these capacitors, from a wide range of digital devices to various circuits.

Table 1 shows the cathode material used in aluminum electrolytic capacitors. Typical aluminum electrolytic capacitors contain a liquid known as the electrolytic solution, and the electric charges move between the electrolytes through ion conduction. In contrast, the conductive polymers developed in recent years make use of electronic conduction to boast a level of conductivity that is 10,000 times higher than that of electrolytic solutions. For that reason, they have been selected for use as the material for solid electrolytic capacitors.

Table 1 also shows the difference when comparing the pyrolysis temperature between the two. In light of environmental issues in recent years, lead-free solders have been introduced, and electronic components are becoming exposed to higher temperatures during the soldering process. As such, there is now a demand for greater resistance to high temperatures for the electronic components. In particular, in the reflow soldering process that involves connecting the electronic components to the circuit board using molten solder, the board that the electronic component is set on must be exposed to temperatures higher than 250°C. Therefore, the electronic component is also exposed to greater heat stress as compared to an implementation that makes use of lead solder. For that reason, conductive polymers with a high level of heat stability, such as PPy (polypyrrole) and



Products that guarantee 3,000 hours at 125°C the chip-type “CX series” (bottom), and the radial lead-type “LX series”



100V conductive polymer aluminum solid electrolytic capacitors—the chip-type “CV series” (bottom), and the radial lead-type “LV series”

NICHICON CORPORATION

PEDOT (polyethylene dioxythiophene), are often selected for use from among the various types of conductive polymers.

Figure 1 shows the internal structure of a conductive polymer aluminum solid electrolytic capacitor. The internal structure does not differ greatly from that of a typical aluminum electrolytic capacitor that uses electrolytic solutions. The only difference lies in whether the electrolyte used in the internal part of the capacitor is a solid (conductive polymer) or a liquid (electrolytic solution). Therefore, an advantage to the conductive polymer aluminum solid electrolytic capacitor is that it can be produced with the same production technologies (winding, assembly) as for typical aluminum electrolytic capacitors.

Table 1: Types of cathode materials and conductivity

Conductivity of electrolytes (S/cm)		Cathode material	Conduction mechanism	Heat resistance
	High 100	PEDOT	Electronic conduction	Pyrolysis temperature: 350°C
	10	PPy	Electronic conduction	Pyrolysis temperature: 300°C
	1	TCNQ complex	Electronic conduction	Pyrolysis temperature: 200 to 240°C
	0.1	MnO ₂	Electronic conduction	α phase transition temperature: 500°C
Low 0.01		Electrolytic solution	Ion conduction	

Figure 1: Internal structure of a conductive polymer aluminum solid electrolytic capacitor



The market's requirements for conductive polymer aluminum solid electrolytic capacitors may be summarized by the following two points.

1) Reliability (long life)

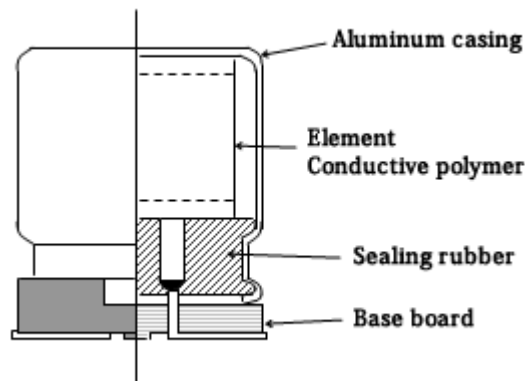
Unlike typical aluminum electrolytic capacitors, conductive polymer aluminum solid electrolytic capacitors do not make use of electrolytic solutions. They do not experience the "dry-up"

NICHICON CORPORATION

phenomenon, whereby the electrolytic solution evaporates from the sealed opening and leaves the inside of the capacitor dry. As such, they are expected to have a long shelf life. In addition, the ion conduction capacity for typical aluminum electrolytic capacitors falls at low temperatures, resulting in an increase in resistance; on the other hand, electronic-conducting conductive polymer aluminum solid electrolytic capacitors are able to maintain a stable level of resistance even at low temperatures. As the conductive polymer aluminum solid electrolytic capacitor is able to maintain its characteristics under its usual temperature over a wide range of temperatures, it is also suitable for use in motor vehicles and other devices that are used outdoors.

Through a review of our manufacturing processes, we have made improvements to the methods of creating conductive polymers. We have also optimized the product through a review of element design and component composition, and developed the chip-type "CX series" (*1) that guarantees 3,000 hours at 125°C over the conventional 105°C, as well as, similarly, the radial lead-type "LX series." The "CX series" lineup is sized at $\phi 6.3 \times 6L$ to $\phi 10 \times 12.7L$ mm, with rated voltage of 16 to 50V, and capacitance range of 5.6~390 μF . The "LX series" lineup is sized at $\phi 8 \times 9L$ to $\phi 10 \times 13L$ mm, with rated voltage of 16 to 50V, and capacitance range of 22~390 μF . With regard to applications, in addition to motor vehicles, the product can also be used in a wide range of devices where a high level of reliability is needed, such as CPU boards for industry use, as well as industrial machinery that require an extended part exchange cycle. By utilizing the merits of the conductive polymer aluminum solid electrolytic capacitor, we have created a product that serves as a solution that can meet market demands.

*1: The $\phi 6.3$ product guarantees 1,500 hours

2) High voltage resistance

The rated voltage for a typical aluminum electrolytic capacitor is established by the voltage resistance of the dielectric and the voltage resistance of the electrolytic solution. If a capacitor with high voltage resistance is needed, aluminum electrolytic capacitors with rated voltage of levels up to 700V are available on the market. These are produced by combining an electrolytic solution with high voltage resistance, with an anode electrode foil that forms a thick dielectric.

The concept behind the establishment of rated voltage is the same for conductive polymer aluminum solid electrolytic capacitors. Manufacturers of set equipment often design the circuit in such a way that the safety factor of the voltage fluctuation is set at 1.5 to 2 times that of the circuit voltage. For instance, the voltage resistance requirement for a capacitor to be installed in a 24V line would be 35~50V.

Through a review of our manufacturing processes, we have made improvements to the methods of creating conductive polymers. We have also enhanced the product's voltage resistance in element design and component composition, and developed the chip-type "CV series" and radial lead-type "LV series" with rated voltage of up to 100V. The "CV series" lineup is sized at $\phi 6.3 \times 6L$ to $\phi 10 \times 12.7L$, with rated voltage of 16 to 100V, and capacitance range of 5.6~470 μF . The "LV series" lineup is sized at $\phi 8 \times 9L$ to $\phi 10 \times 13L$ mm, with rated voltage of 16~100V, and capacitance range of 6.8~470 μF .

Even as the market is drawn by the merits of the conductive polymer aluminum solid electrolytic capacitor, there are many circuits into which it cannot be introduced due to limitations in the maximum rated voltage. With the increase in the range of rated voltage as described above, the product will be able to make the breakthrough into a wide range of circuits in addition to circuits that already make use of the conductive polymer aluminum solid electrolytic capacitor. Our company will continue with its development efforts with a view to developing products for even higher voltages.

NICHICON CORPORATION

The characteristics that will be required of future conductive polymer aluminum solid electrolytic capacitors may be summarized as follows.

1) Low ESR

There have been calls to enhance some of the characteristics of conductive polymers, and one of these is the reduction of ESR in high frequencies. Low resistance can contribute to the suppression of heat generation through ripple currents. For electrolytic capacitors, heat generation is a factor that can impact directly on their life span, and a lower degree of heat generation is linked directly to a longer life span. Our company has released ultralow ESR products onto the market, including the chip-type "CK series" and the radial lead-type "LE series."

2) Compact, with larger capacitance

As set equipment become increasingly smaller and thinner, the demand for smaller parts has become a constant call among set equipment manufacturers. For products with the same capacitance, smaller products are in demand; for products that are of the same size, greater capacitance is demanded. Our company has released onto the market the chip-type "CG series" and the radial lead-type "LG series" that boast capacitance of approximately 3-4 times that of standard products of the same size. Comparing these with products that have the same capacitance, we have successfully achieved sizes that are 1-2 ranks smaller.

3) High voltage resistance

Conductive polymer aluminum solid electrolytic capacitors have been adopted mainly for use in power circuits. However, use of these capacitors in other digital devices, motor vehicles, and industrial machinery has also grown, and accompanying that is an increasing demand for stronger voltage resistance. One of the characteristics of the conductive polymer aluminum solid electrolytic capacitor is its ability to maintain low ESR despite its high voltage resistance, and such products are in demand. The abovementioned "CV and LV series," for instance, occupy a product domain that is completely unprecedented, and the company is continuously reviewing new product types in addition to replacement products for other types of capacitors.

Winding-type conductive polymer aluminum solid electrolytic capacitors are characterized by a larger capacitance per unit of surface area as compared to other capacitors. Winding-type conductive polymer aluminum solid electrolytic capacitors are able to make effective use of vertical spaces, and are able to fulfill requirements with a small number of installed components. Compared to tantalum solid electrolytic capacitors and laminated ceramic capacitors, winding-type conductive polymer aluminum solid electrolytic capacitors also have a higher capacitance density ratio per unit of surface area, and are thus a perfect match for the developmental trends of set equipment manufacturers, with their aim for smaller sets and lower costs.

Conductive polymer aluminum solid electrolytic capacitors have a wide range of applications, from flat-screen televisions to the motherboard of computers. They also have characteristics that make them suitable for use in multicore systems with high-speed computing capabilities, Blu-ray disc devices, and other forms of the latest devices. From this perspective, much can be expected from the conductive polymer aluminum solid electrolytic capacitor in the future. With a view to further expanding our market segment, our company will continue to make efforts toward making advancements in developing products of smaller sizes and larger capacitance, low ESR, high voltage resistance, a high level of reliability, and ability to withstand strong temperatures.

Daihei Yamauchi (Nichicon (Fukui) Corporation, Engineering Department)