



# Wireless Communication

Application Guide 2021



[www.infineon.com/rf](http://www.infineon.com/rf)



## About this Application Guide

This Application Guide for Wireless Communication describes recent trends in Wireless Radio Frequency (RF) applications and includes suggestions for designing RF Frontends with our latest devices. The following subjects are covered within this guide:

1. Overview of the Infineon Technologies' RF product portfolio
2. RF devices for cellular communication
3. RF devices for Global Navigation Satellite Systems (GNSS), Wireless LAN routers.
4. RF devices for wireless broadcasting systems FM radio, SDARs and mobile TVs
5. Electro-Static Discharge (ESD) protection devices for digital and RF interfaces in mobile communication devices

## Infineon Technologies

# A Leading Company in RF and Sensors

Infineon Technologies has more than 60 years of experience in developing RF products for numerous applications. The Radio Frequency & Sensors (RFS) business unit has evolved over the years from supplying standard RF discrete components to providing an advanced portfolio of innovative and differentiated products including application-specific Microwave Monolithic Integrated Circuits (MMICs), millimeter-wave (mmW) transceivers, a large variety of high-end sensors and ESD protection components. RFS solutions for mobile device, cellular infrastructure, sensing, radar & 3D imaging applications shape the way we live and work. Please visit the home pages of "[RF & Wireless Control](#)", "[Sensor](#)" or "[ESD and Surge Protection](#)" to learn more.

In this application guide, we have summarized the major available application circuits and their performance for the key application area Wireless Communication. For your convenience, the Internet product pages and application notes can be reached by simply clicking on any device in the tables of recommended devices.

Our application experts worldwide are always ready to help you design your systems with our devices. Please contact [Infineon's Regional Offices](#) or one of [Infineon Worldwide Distribution Partners](#) in your area to get all the support you might need.

Kind regards,  
Mathias Wolfmueller  
Head of Application Engineering RF Communication



# Contents

<b>1</b>	<b>Infineon's RF and Protection Devices for Wireless Communication Systems</b>	<b>4</b>
1.1	Benefits of Our RF Solutions for Your System	6
<b>2</b>	<b>Cellular Communication in Mobile Devices</b>	<b>7</b>
2.1	Antenna Centric Solutions	8
2.1.1	Antenna Tuners	8
2.1.2	Cross Switches	9
2.1.3	Bi-directional Coupler	10
2.2	RF Switches	11
2.2.1	Ultra-High Linearity RF Switches	11
2.2.2	Diversity RF Switches	11
2.3	Low Noise Amplifiers	13
2.3.1	Single-band LNAs	13
2.3.2	LNAs with Multiple Gain States	14
2.4	Switch + LNA Modules	16
2.5	RF FE Devices for 3.5 GHz TD-LTE	17
<b>3</b>	<b>Global Navigation Satellite Systems</b>	<b>18</b>
3.1	GNSS-Enabled Smart Phones and Wearable Devices	19
3.2	GNSS-Enabled Active Antenna Modules	20
<b>4</b>	<b>Wireless-LAN, Unlicensed LTE (LTE-U) and Licensed Assisted Access (LAA)</b>	<b>21</b>
4.1	Wireless-LAN Routers and Access Points	21
4.2	Unlicensed LTE (LTE-U) and Licensed Assisted Access (LAA)	23
<b>5</b>	<b>FM Radio, SDARS and Mobile TV</b>	<b>25</b>
5.1	FM Radio in Mobile Devices and Cars	25
5.2	SDARS and HD Radio	26
5.3	TV Reception in Mobile Devices	27
<b>6</b>	<b>Wearables and LiDAR</b>	<b>28</b>
6.1	Wearables	28
6.2	LiDAR	29
<b>7</b>	<b>Interface protection against ESD/Surge</b>	<b>30</b>
<b>8</b>	<b>Support Material</b>	<b>33</b>
<b>9</b>	<b>Abbreviations</b>	<b>34</b>
<b>10</b>	<b>Package Information</b>	<b>35</b>

# 1 Infineon's RF and Protection Devices for Wireless Communication Systems

Wireless communication devices represent the largest worldwide market in terms of both volume and number of applications on a single platform. For example, wireless communication functions in a smart phone include a cellular modem, Wi-Fi modem, Bluetooth, Global Navigation Satellite System (GNSS), Ultra-Wide Band (UWB), Near-Field Communication (NFC) and entertainment systems such as FM radio and mobile TV.

Infineon addresses requirements for high-performance mobile communication devices and wireless systems by offering RF MMIC LNAs, RF CMOS switches, antenna-tuning devices, RF couplers, RF transistors and diodes. We also offer a comprehensive portfolio for Electro-Static Discharge (ESD)/Electromagnetic Interference (EMI) protection. Figure 1 and Figure 2 illustrate the available product portfolio for a smart phone RF Frontend.

In addition to the above listed components, Infineon also provides XENSIV™ MEMS microphones for mobile devices.

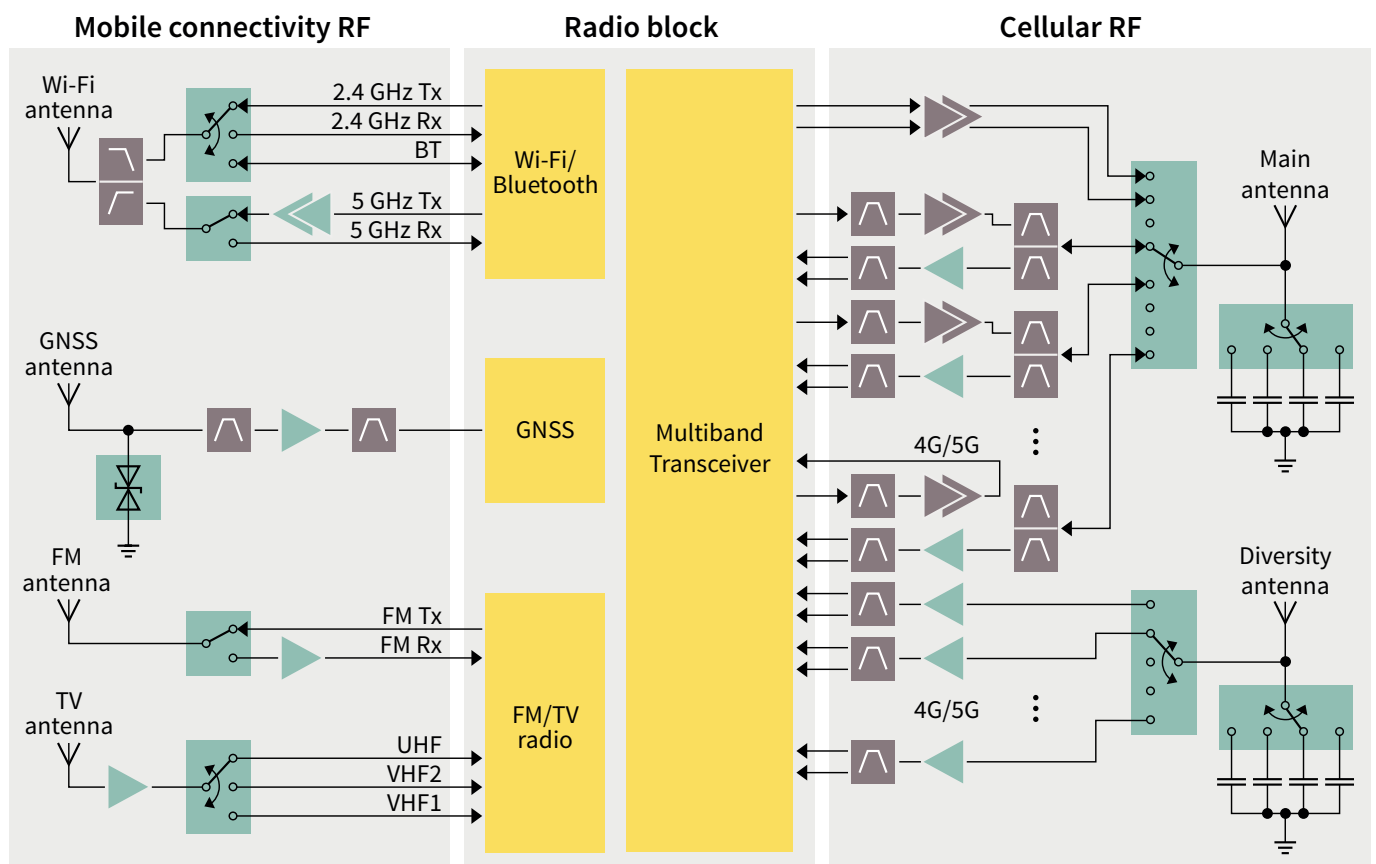

Figure 1 Overview of Infineon's products for a smart phone RF Frontend

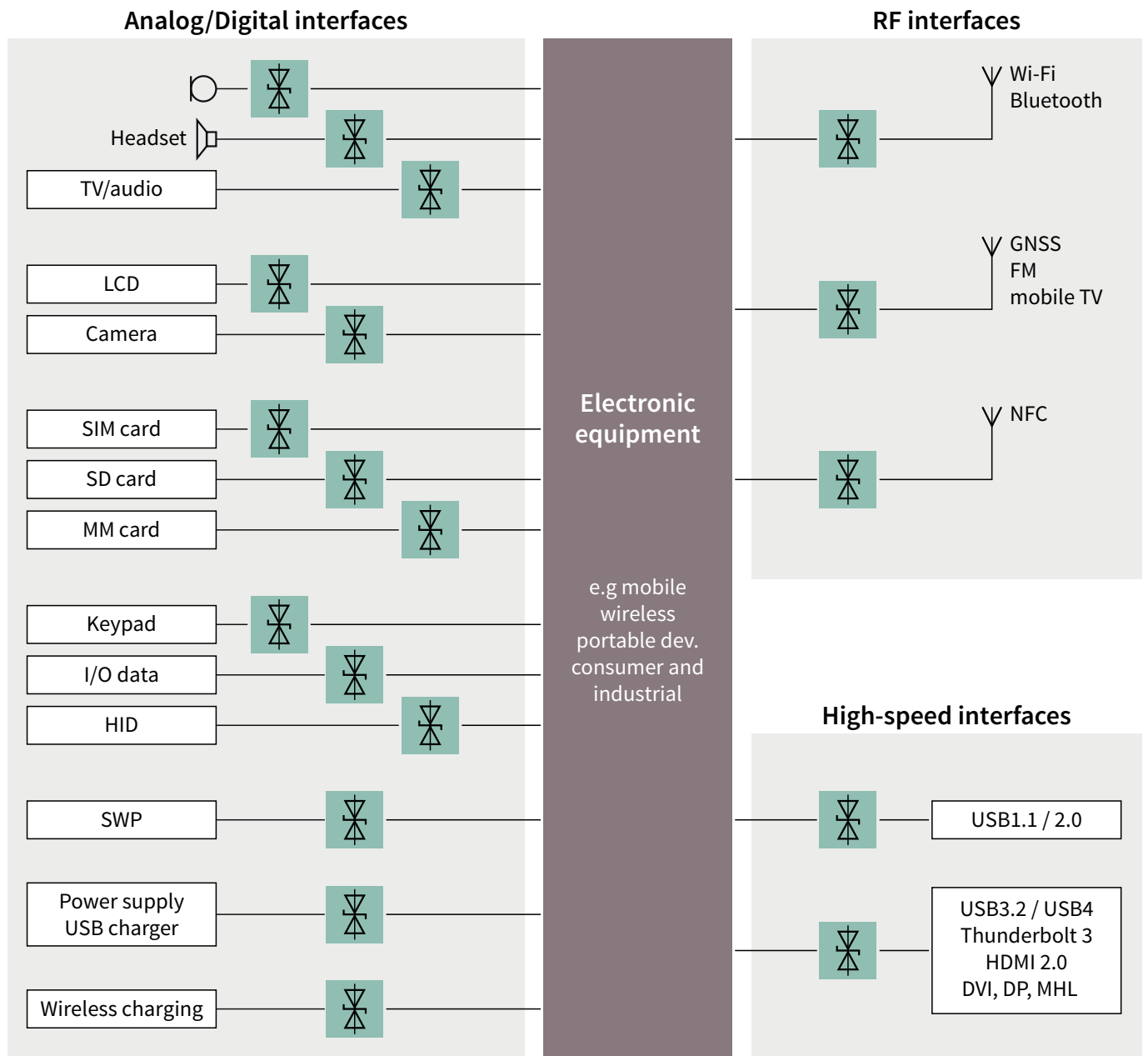









Figure 2 Overview of Infineon’s ESD protection devices

## 1.1 Benefits of our RF Solutions for your System

Infinion RF Solutions are designed to meet customers' system needs for highest RF performance and reliable wireless connectivity. In this way, we support your devices to achieve higher data rates, better quality signal, and longer battery lifetime.





	Antenna tuning	Antenna matching	Antenna selection	Antenna detection	RF switch	LNA	GPS LNA	ESD protection
Function	 Tune	 Match	 Swap	 Detect	 Select	 Amplify	 Position	 Protect
Benefits	Tuning an antenna to a specific frequency band for <b>optimized performance with lowest number of antennas</b>	<b>Optimizing signal transmission to the antenna</b> by compensating frequency and environmental effects	Adapting the application to the user behaviour by <b>selecting the best performing antenna</b>	<b>Enabling control of an antenna</b> by providing signal power information to or from the antenna	<b>Optimizing data transmission</b> by selecting the best signal path (frequency)	Amplifying weak incoming signals for <b>best data transmission</b>		<b>Protecting system interfaces</b> from being destroyed by ESD damage
Systems								
5G/4G cellular	Antenna tuner	Antenna tuner C-tuner	High power switch cross switch	Coupler	RF switch	5G/4G LNA		TVS diodes
Wi-Fi/BT UWB				RF Schottky diode	<ul style="list-style-type: none"> <li>› PIN diode</li> <li>› RF switch</li> </ul>	Discrete RF transistor		TVS diodes
GNSS							<ul style="list-style-type: none"> <li>› Integr. GPS LNA</li> <li>› Discrete RF transistor</li> </ul>	TVS diodes

Please visit <https://www.infineon.com/rf> to discover our full portfolio.

## 2 Cellular Communication in Mobile Devices

In this chapter, we would like to present the available devices for cellular phones and other cellular enabled mobile devices. With rich development experience for RF products, application know-how, an expanding product portfolio,

and established industry contacts and partners, our components enable a high performance, high efficiency RF frontend with innovation.

 <p><b>Higher data rate</b></p> <ul style="list-style-type: none"> <li>› Up to 40% higher data rate with external LNAs</li> <li>› Tuned antenna for best performance</li> <li>› 5G features enabled</li> <li>› DLCA, ULCA and ENDC supported</li> </ul>	 <p><b>Wider coverage</b></p> <ul style="list-style-type: none"> <li>› Up to 40% area coverage extension With external LNAs</li> <li>› Global operating frequency bands supported</li> </ul>	 <p><b>More power efficiency</b></p> <ul style="list-style-type: none"> <li>› Up to 50% PA power saving due to antenna Tuning and swapping</li> <li>› Low product level DC Power consumption</li> </ul>	 <p><b>Higher system robustness</b></p> <ul style="list-style-type: none"> <li>› Well protected from ESD event</li> <li>› Reduced antenna hand&amp;head effect</li> <li>› Less sensitive to jammer signals</li> </ul>
 <p><b>Infineon's high quality cellular solutions</b></p>			



## 2.1 Antenna Centric Solutions

### 2.1.1 Antenna Tuners

In smart connected devices, an antenna should be able to perform well in several frequency bands. Hence there is a growing need to tune antennas according to the selected frequency bands. This can be done by applying Antenna Tuning which improves the overall antenna radiation efficiency. All Infineon Antenna Tuners are suitable for 5G application.

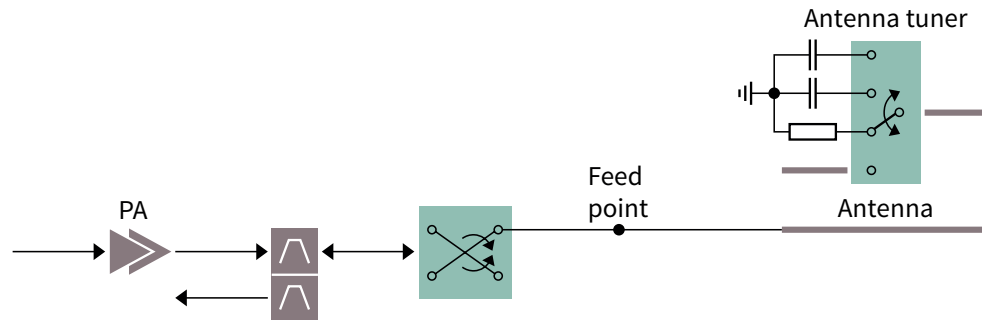

Figure 3 Antenna tuning application

#### Antenna Tuners for Best Antenna Efficiency

Product	Type	App. note	Supply $V_{DD}$ [V]	Supply $V_{IO}$ [V]	$V_{ctrl}^{1)}$ [V]	$R_{on}^{2)}$ [ $\Omega$ ]	$C_{OFF}^{3)}$ [fF]	$V_{RFmax}^{4)}$ [V]	Control Interface	Package
<a href="#">BGSA11GN10</a>	2xSPST	on request	1.65...3.6	-	0...2.85	1.0	250	36	GPIO	TSNP-10
<a href="#">BGSA12GN10</a>	SPDT	on request	1.65...3.6	-	0...2.85	1.6	120	36	GPIO	TSNP-10
<a href="#">BGSA12UGL8</a>	SPDT	on request	1.65...3.6	-	0...2.85	0.59	270	40	GPIO	TSLP-8
<a href="#">BGSA14GN10</a>	SP4T	on request	1.65...3.6	-	0...2.85	1.6	120	36	GPIO	TSNP-10
<a href="#">BGSA143ML10</a>	SP4T <sup>5)</sup>	on request	-	1.65...1.95	-	1.15	140	42	RFFE MIPI	TSLP-10
<b>NEW</b> <a href="#">BGSA143GL10</a>	SP4T <sup>5)</sup>	on request	1.65...3.6	-	0...2.85	1.15	140	42	GPIO	TSLP-10
<b>NEW</b> <a href="#">BGSA147ML10</a>	SP4T <sup>5)</sup>	on request	-	1.65...1.95	-	0.8	155	45	RFFE MIPI	TSLP-10
<b>NEW</b> <a href="#">BGSA402ML10</a>	4xSPST <sup>6)</sup>	on request	1.65...3.6	1.65...1.95	-	1.49	170	45	RFFE MIPI	TSLP-10
<b>NEW</b> <a href="#">BGSA20VGL8</a>	2xSPST <sup>6)</sup>	on request	1.65...3.6	-	0...2.85	1.6	240	67	GPIO	TSLP-8
<b>NEW</b> <a href="#">BGSA20UGL8</a>	2xSPST <sup>6)</sup>	on request	1.65...3.6	-	0...2.85	2.3	200	80	GPIO	TSLP-8
<b>NEW</b> <a href="#">BGSA142GN12</a>	SP4T	on request	1.65...3.6	-	0...2.85	1.75	110	72	GPIO	TSNP-12
<b>NEW</b> <a href="#">BGSA142MN12</a>	SP4T <sup>7)</sup>	on request	-	1.65...1.95	-	1.75	110	72	RFFE MIPI	TSNP-12
<a href="#">BGSA142M2N12</a>	SP4T <sup>8)</sup>	on request	1.65...3.6	1.65...1.95	-	1.75	110	72	RFFE MIPI	TSNP-12

1) Digital Control Voltage

2) Single RF path ON mode

3) Single RF path OFF mode

4) Max RF Voltage

5) With shunt switches (Resonance stopper)

6) Shunt to ground

7) Single VIO

8) VDD + VIO

## 2.1.2 Cross Switches

The Figure 4 shows a typical application for a cross switch in a mobile phone. This device allows a designer to select the best performing antenna for optimizing transmit power for an Up-Link (UL) or improved receive sensitivity for a Down-Link (DL).

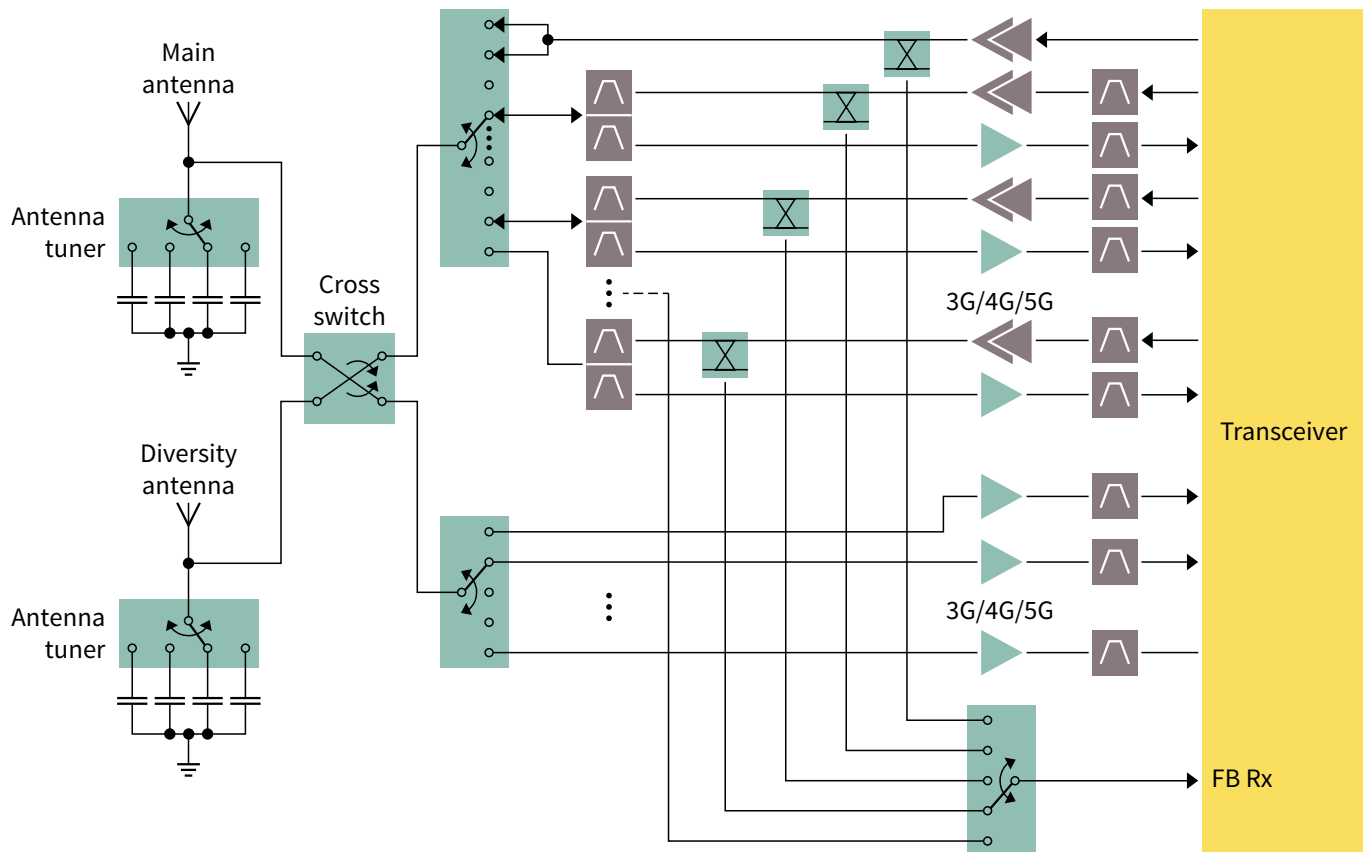

Figure 4 An example of cross switch application

### Cross Switches for Antenna Selection

Product	Type	App. note	Supply $V_{DD}$ [V]	$V_{ctrl}^{1)}$ [V]	IL <sup>2)</sup> [dB]	Isolation <sup>3)</sup> [dB]	$P_{in,max}^{4)}$ [dBm]	Control Interface	Package
<a href="#">BGSX22G5A10</a>	DPDT	on request	1.65...3.4	1.35... $V_{DD}$	0.28/0.37	41/34	37	GPIO	ATSLP-10
<b>NEW</b> <a href="#">BGSX33MU16</a>	3P3T	on request	1.65...3.4	RFFE MIPI	0.35/0.45	42/37	36.5	RFFE MIPI	ULGA-16
<b>NEW</b> <a href="#">BGSX24MU16</a>	DP4T	on request	1.65...3.4	RFFE MIPI	0.40/0.45	48/41	36.5	RFFE MIPI	ULGA-16

1) Digital Control Voltage (logic high)

2) IL = Insertion Loss at 1.0/2.0 GHz

3) Isolation at 1.0/2.0 GHz

4) Maximum input power

6) Please contact your local Infineon or sales representatives for further products

### 2.1.3 Bi-directional Coupler

A bi-directional coupler in RF front-ends of cellular phones is located between a power amplifier/antenna switch module (PA/ASM) and an antenna tuner. The coupler is used as a part of the power control and antenna tuning loops.

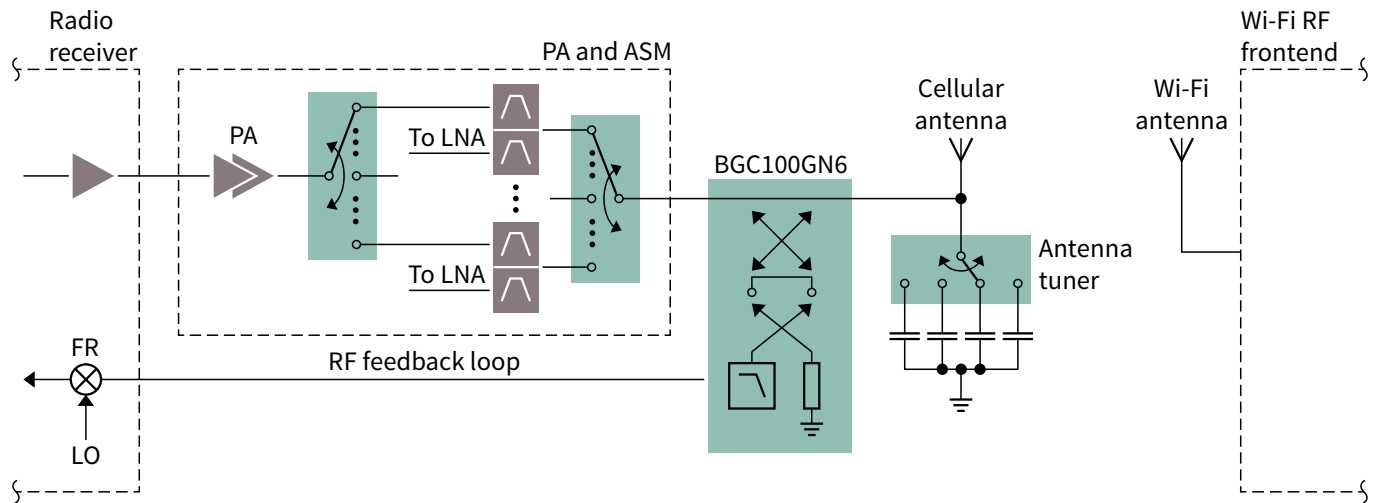

Figure 5 Block diagram of a cellular RF frontend

#### Bi-directional Coupler

Product	Frequency [GHz]	IL @ 2.7 GHz [dB]	Coupling Factor @ 2.7 GHz [dB]	Directivity @ 2.7 GHz [dB]	Max RF Input Power @ 2.7GHz [dBm]	Control Interface	Size [mm <sup>2</sup> ]	Package
<a href="#">BGC100GN6</a>	0.6-2.7	0.2	23	25	29	GPIO	1.1 × 0.7	TSNP-6



## 2.2 RF Switches

Infineon's RF switches portfolio includes high-performance devices with low Insertion Loss (IL), high isolation and low harmonics generation. The RF switches are used for band selection and switching or diversity switching at the antenna or different RF paths within the RF (FE). These devices are manufactured using Infineon's patented MOS technology, with power capability up to +39 dBm.

### 2.2.1 Ultra-High Linearity RF Switches

Below types feature high power handling capability, combining with excellent insertion loss and isolation performance, well fit for mobile phones or data cards.

#### Ultra-High Linearity/High Power Switches

Product	Type	App. note	V <sub>DD</sub> [V]	V <sub>ctrl</sub> <sup>1)</sup> [V]	IL <sup>2)</sup> [dB]	Isolation <sup>3)</sup> [dB]	P <sub>in,max</sub> <sup>4)</sup> [dBm]	Control Interface	Package
<b>NEW</b> BGS12PL6	SPDT	AN319	2.4...3.6	1.4...V <sub>DD</sub>	0.36/0.46	37/30	35	GPIO	TSLP-6
BGS12P2L6	SPDT	on request	1.65...3.4	1.35...V <sub>DD</sub>	0.20/0.25	45/39	37	GPIO	TSLP-6
BGS12PN10	SPDT	AN497	1.8 – 3.6	1.2...2.85	0.16/0.22	39/32	38	GPIO	TSNP-10
BGS14PN10	SP4T	AN498	1.8 – 3.6	1.2...2.85	0.18/0.29	41/32	38	GPIO	TSNP-10
<b>NEW</b> BGS14MPA9	SP4T	on request	1.65...1.95	RFFE MIPI	0.20/0.24	47/38	37	RFFE MIPI	ATSLP-9

1) Digital Control Voltage (logic high)

2) IL = Insertion Loss at 1.0/2.0 GHz

3) Isolation at 1.0/2.0 GHz from RF<sub>in</sub> to RF port

4) Maximum input power

5) Please visit [www.infineon.com/rfswitches](http://www.infineon.com/rfswitches) for alternative devices.

### 2.2.2 Diversity RF Switches

The recent trend of mobile device users to download data at a higher rate requires a higher bandwidth and an additional receiver channel called the diversity path. To select the right receive band, one option is to use a diversity switch with low insertion loss and excellent RF performance. Diversity switches are more frequently used in smartphones and tablets.

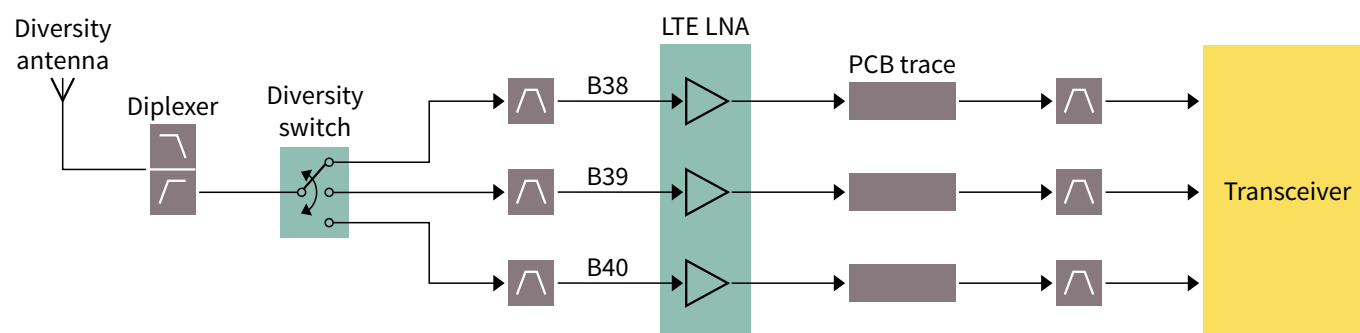

Figure 6 Example of TD-LTE band for diversity path

## RF CMOS Switches for Diversity Antenna

	Product	Type	App. note	V <sub>DD</sub> [V]	V <sub>ctrl</sub> <sup>1)</sup> [V]	IL <sup>2)</sup> [dB]	Isolation <sup>3)</sup> [dB]	P <sub>in,max</sub> <sup>4)</sup> [dBm]	Control Interface	Package
	<a href="#">BGS12SN6</a>	SPDT	<a href="#">AN332</a>	1.8...3.5	1.35...V <sub>DD</sub>	0.25 / 0.28	40 / 32	30	GPIO	TSNP-6
NEW	<a href="#">BGS12WN6</a>	SPDT	on request	1.65...3.6	1.35...V <sub>DD</sub>	0.16 / 0.19	46 / 39	26	GPIO	TSNP-6
	<a href="#">BGS13S4N9</a>	SP3T	on request	1.8...3.3	1.35...V <sub>DD</sub>	0.20 / 0.30	31 / 20	30	GPIO	TSNP-9
	<a href="#">BGS14MA11</a>	SP4T	on request	1.7...3.4	RFFE MIPI	0.20 / 0.23	40 / 35	34	RFFE MIPI	ATSLP-11
NEW	<a href="#">BGS14WMA9</a>	SP4T	on request	1.65...1.95	RFFE MIPI	0.22 / 0.27	46 / 39	26	RFFE MIPI	ATSLP-9
NEW	<a href="#">BGS15MU14</a>	SP5T	on request	1.65...1.95	RFFE MIPI	0.48 / 0.55	62 / 56	20	RFFE MIPI	ULGA-14
	<a href="#">BGS16GA14</a>	SP6T	<a href="#">AN481</a>	2.4...3.4	1.35...V <sub>DD</sub>	0.23 / 0.36	50 / 41	28	GPIO	ATSLP-14
NEW	<a href="#">BGS16MN14</a>	SP6T	<a href="#">AN368</a>	2.5...5.5	RFFE MIPI	0.30 / 0.40	42 / 37	27	RFFE MIPI	TSNP-14
NEW	<a href="#">BGS18MA14</a>	SP8T	on request	1.7...3.4	RFFE MIPI	0.30 / 0.35	45 / 37	32	RFFE MIPI	ATSLP-14
NEW	<a href="#">BGS18MN14</a>	SP8T	<a href="#">AN366</a>	2.5...5.5	RFFE MIPI	0.30 / 0.50	40 / 32	27	RFFE MIPI	TSNP-14
	<a href="#">BGS18GA14</a>	SP8T	<a href="#">AN483</a>	2.4...3.4	1.35...V <sub>DD</sub>	0.27 / 0.42	50 / 41	28	GPIO	ATSLP-14

1) Digital Control Voltage (logic high)

2) IL = Insertion Loss at 1.0/2.0 GHz

3) Isolation at 1.0/2.0 GHz from RF<sub>in</sub> to RF port

4) Maximum input power

5) Please visit [www.infineon.com/rfswitches](http://www.infineon.com/rfswitches) for alternative devices.

## RF CMOS Switches for Diversity Antenna

	Product	Type	App. note	V <sub>DD</sub> [V]	V <sub>ctrl</sub> <sup>1)</sup> [V]	IL <sup>2)</sup> [dB]	Isolation <sup>3)</sup> [dB]	P <sub>in,max</sub> <sup>4)</sup> [dBm]	Control Interface	Package
NEW	<a href="#">BGSX44MA12</a>	4P4T	on request	1.65...1.95	RFFE MIPI	0.45 / 0.60	46 / 40	25	RFFE MIPI	ATSLP-12
	<a href="#">BGSX210MA18</a>	DP10T	on request	2.5...3.4	RFFE MIPI	0.30 / 0.45	36 / 26	27	RFFE MIPI	ATSLP-18
	<a href="#">BGSX212MA18</a>	DP12T	on request	2.5...3.4	RFFE MIPI	0.30 / 0.45	36 / 26	27	RFFE MIPI	ATSLP-18

1) Digital Control Voltage (logic high)

2) IL = Insertion Loss at 1.0/2.0 GHz

3) Isolation at 1.0/2.0 GHz from RF<sub>in</sub> to RF port

4) Maximum input power

5) Please visit [www.infineon.com/rfswitches](http://www.infineon.com/rfswitches) for alternative devices.

## 2.3 Low Noise Amplifiers

Infineon has been one of the earliest companies developing Low Noise Amplifiers (LNAs) in Silicon Germanium (SiGe) based and Silicon Germanium Carbon (SiGe:C) based technology. Our Monolithic Microwave Integrated Circuit (MMIC) LNAs and Switch + LNA Modules feature excellent low noise figures, and offer system layout flexibility by suppressing noise contribution from losses of signal lines and from the filters as well as the receiver. High linearity assures optimal signal reception even with poorly isolated antennas and long line losses between antennas and transceivers. In very weak signal environment, LNAs can enhance the system sensitivity up to 3 dB, and double the data rates compared to solutions without LNAs.

### 2.3.1 Single-band LNAs

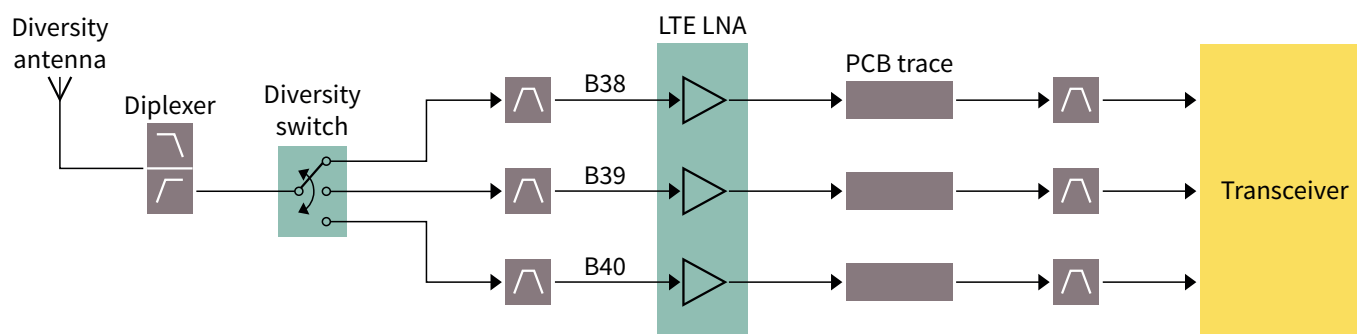

Figure 7 Three single-band LNAs implemented in the diversity path

### Single-band LTE MMIC LNAs with Bypass Functions

Product	Freq. Range [MHz]	Gain <sup>2)</sup> [dB]	NF <sup>2)</sup> [dB]	IP <sub>-1dB</sub> <sup>2)</sup> [dBm]	IIP <sub>3</sub> <sup>2)</sup> [dBm]	Supply V <sub>DD</sub> [V]	Current <sup>2)</sup> [mA]	Package
<a href="#">BGA5L1BN6<sup>1)</sup></a>	600–1000	18.5 / -2.7	0.7 / 2.7	-20 / +2	-7 / +11	1.5...3.6	8.2 / 0.085	TSNP-6-2
<a href="#">BGA5M1BN6<sup>1)</sup></a>	1805–2200	19.3 / -4.7	0.65 / 4.7	-17 / -2	-7 / +6	1.5...3.6	9.5 / 0.085	TSNP-6-2
<a href="#">BGA5H1BN6<sup>1)</sup></a>	2300–2690	18.1 / -5.2	0.7 / 5.2	-17 / -3	-7 / +6	1.5...3.6	8.5 / 0.085	TSNP-6-2
<a href="#">BGA7L1BN6<sup>1)</sup></a>	716–960	13.6 / -2.2	0.75 / 1.8	-1 / +6	+5 / +18	1.5...3.3	4.9 / 0.09	TSNP-6-2
<a href="#">BGA7H1BN6<sup>1)</sup></a>	1805–2690	11 / -3.5	0.85 / 2.7	-1 / +5	+5 / +16	1.5...3.3	4.3 / 0.09	TSNP-6-2
<a href="#">BGA729N6</a>	70–600	16.0 / -4.0	1.05 / 4.3	-15 / +4	-6 / +20	1.5...3.3	6.3 / 0.55	TSNP-6-2

1) LNA with two gain modes (high-gain/low-gain)

2) Values in high-gain (HG)/low-gain (LG) mode

3) Please visit <https://www.infineon.com/cms/en/product/rf-wireless-control/low-noise-amplifier-lna-ics/lte-3g-lnas/> for alternative devices.

### Single-band LTE MMIC LNAs

Product	App. note	Freq. Range [MHz]	Gain [dB]	NF [dB]	IP <sub>-1dB</sub> [dBm]	IIP <sub>3</sub> [dBm]	Supply V <sub>DD</sub> [V]	Current [mA]	Package
<a href="#">BGA7L1N6</a>	<a href="#">AN351</a> <a href="#">AN364</a> <a href="#">AN404</a>	728–960	13.0	0.9	-6	-1	1.5...3.3	4.5	TSNP-6-2
<a href="#">BGA7M1N6</a>	<a href="#">AN350</a> <a href="#">AN371</a> <a href="#">AN405</a> <a href="#">AN411</a>	1805–2200	13.0	0.7	-3	7	1.5...3.3	4.5	TSNP-6-2
<a href="#">BGA7H1N6</a>	<a href="#">AN349</a> <a href="#">AN365</a> <a href="#">AN406</a> <a href="#">AN432</a>	2300–2690	13.0	0.7	-4	6	1.5...3.3	4.7	TSNP-6-2

1) Please visit <https://www.infineon.com/cms/en/product/rf-wireless-control/low-noise-amplifier-lna-ics/lte-3g-lnas/> for alternative devices.

## 2.3.2 LNAs with Multiple Gain States

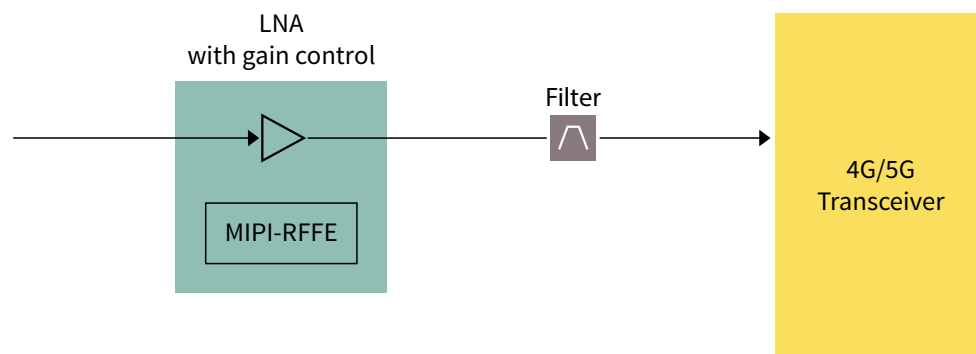

Figure 8 Multi gain state LNA implemented in the main path

## MIPI LNA with Gain Control for 4G/5G

Product	Freq. Range [MHz]	Gain [dB]	NF [dB]	IP <sub>-1dB</sub> [dBm]	IIP <sub>3</sub> [dBm]	Supply V <sub>DD</sub> [V]	Current [mA]	Package
BGAU1A10 <sup>1)</sup>	3400–3800	18.0 <sup>2)</sup>	1.3 <sup>2)</sup>	-13 <sup>2)</sup>	-3 <sup>2)</sup>	1.7...1.9	5.0 <sup>2) 3) 4) 5)/0.07<sup>6)</sup></sup>	ATSLP-10-1
		15.3 <sup>3)</sup>	1.4 <sup>3)</sup>	-13 <sup>3)</sup>	-3 <sup>3)</sup>			
		8.9 <sup>4)</sup>	1.5 <sup>4)</sup>	-6 <sup>4)</sup>	+1 <sup>4)</sup>			
		-0.7 <sup>5)</sup>	10.1 <sup>5)</sup>	+3 <sup>5)</sup>	+9 <sup>5)</sup>			
		-3.9 <sup>6)</sup>	3.9 <sup>6)</sup>	–	+32 <sup>6)</sup>			
BGAU1A10 <sup>1)</sup>	5150–5920	20.5 <sup>2)</sup>	1.7 <sup>2)</sup>	-18 <sup>2)</sup>	-8 <sup>2)</sup>	1.6...1.9	5.0 <sup>2) 3) 4) 5)/0.1<sup>6)</sup></sup>	ATSLP-10-1
		17.5 <sup>3)</sup>	1.7 <sup>3)</sup>	-17 <sup>3)</sup>	-8 <sup>3)</sup>			
		9.0 <sup>4)</sup>	1.6 <sup>4)</sup>	-6 <sup>4)</sup>	-2 <sup>4)</sup>			
		-0.3 <sup>5)</sup>	9.9 <sup>5)</sup>	+3 <sup>5)</sup>	+6 <sup>5)</sup>			
		-6.5 <sup>6)</sup>	6.5 <sup>6)</sup>	–	+30			

1) AN on request

2) Gain state: G0

3) Gain state: G1

4) Gain state: G2

5) Gain State: G3

6) Gain G4

7) Gain state: G5

8) Gain state: G6

9) Gain state: Bypass

10) Based on preliminary datasheet

Please visit <https://www.infineon.com/cms/en/product/rf-wireless-control/low-noise-amplifier-lna-ics/lte-3g-lnas/> for alternative devices.

## MIPI LNA with Gain Control for 4G/5G (cont'd)

Product	Freq. Range [MHz]	Gain [dB]	NF [dB]	IP <sub>-1dB</sub> [dBm]	IIP <sub>3</sub> [dBm]	Supply V <sub>DD</sub> [V]	Current [mA]	Package	
NEW	BGAH1A10	2300–2690	18.1 <sup>2)</sup>	1.1 <sup>2)</sup>	-11 <sup>2)</sup>	-1 <sup>2)</sup>	1.7...1.9	5.0 <sup>2)3)4)5)/0.07<sup>10)</sup></sup>	ATSLP-10-1
			15.3 <sup>3)</sup>	1.15 <sup>3)</sup>	-11 <sup>3)</sup>	-2 <sup>3)</sup>			
			10.0 <sup>4)</sup>	1.2 <sup>4)</sup>	0 <sup>4)</sup>	3 <sup>4)</sup>			
			0.2 <sup>5)</sup>	10.0 <sup>5)</sup>	>0 <sup>5)</sup>	11 <sup>5)</sup>			
			-2.5	2.5 <sup>10)</sup>		26			
NEW	BGA9H1MN9 <sup>10)</sup>	1400–2700	17.1 <sup>2)</sup>	1.01 <sup>2)</sup>	-14.6 <sup>2)</sup>	-7.3 <sup>2)</sup>	1.2...1.8	3.5 <sup>2)3)4)5)6)7)8)</sup>	TSNP-9-2
			14.6 <sup>3)</sup>	1.01 <sup>3)</sup>	-13.9 <sup>3)</sup>	-7.1 <sup>3)</sup>			
			13.0 <sup>4)</sup>	1.34 <sup>4)</sup>	-12.3 <sup>4)</sup>	-4.9 <sup>4)</sup>			
			10.5 <sup>5)</sup>	1.53 <sup>5)</sup>	-12.1 <sup>5)</sup>	-4.9 <sup>5)</sup>			
			7.3 <sup>6)</sup>	1.92 <sup>6)</sup>	-12.1 <sup>6)</sup>	-5.1 <sup>6)</sup>			
			-1.6 <sup>7)</sup>	10.47 <sup>7)</sup>	-0.4 <sup>7)</sup>	9.7 <sup>7)</sup>			
			-2.8 <sup>8)</sup>	4.10 <sup>8)</sup>	5.3 <sup>8)</sup>	20.3 <sup>8)</sup>			
NEW	BGA9V1MN9 <sup>10)</sup>	3300–4200	21.0 <sup>2)</sup>	0.75 <sup>2)</sup>	-18 <sup>2)</sup>	-6 <sup>2)</sup>	1.1...2.0	3.5 <sup>2)3)4)5)6)7)8)9)</sup>	TSNP-9-2
			18.0 <sup>3)</sup>	0.8 <sup>3)</sup>	-17 <sup>3)</sup>	-3 <sup>3)</sup>			
			14.9 <sup>4)</sup>	1.0 <sup>4)</sup>	-16 <sup>4)</sup>	-3 <sup>4)</sup>			
			11.9 <sup>5)</sup>	1.15 <sup>5)</sup>	-16 <sup>5)</sup>	-3 <sup>5)</sup>			
			8.5 <sup>6)</sup>	1.4 <sup>6)</sup>	-16 <sup>6)</sup>	-3 <sup>6)</sup>			
			-2.7 <sup>7)</sup>	11.0 <sup>7)</sup>	1 <sup>7)</sup>	8 <sup>7)</sup>			
			-3.0 <sup>8)</sup>	3.0 <sup>8)</sup>	–	–			
NEW	BGA9C1MN9 <sup>10)</sup>	4400–5500	19.0 <sup>2)</sup>	0.9 <sup>2)</sup>	-17 <sup>2)10)</sup>	-5 <sup>2)</sup>	1.1...2.0	3.5 <sup>2)3)4)5)6)7)8)9)</sup>	TSNP-9-2
			16.0 <sup>3)</sup>	0.95 <sup>3)</sup>	-17 <sup>3)10)</sup>	-5 <sup>3)</sup>			
			12.5 <sup>4)</sup>	1.3 <sup>4)</sup>	-12 <sup>4)10)</sup>	-1 <sup>4)</sup>			
			9.6 <sup>5)</sup>	1.45 <sup>5)</sup>	-12 <sup>5)10)</sup>	0 <sup>5)</sup>			
			6.1 <sup>6)</sup>	1.85 <sup>6)</sup>	-12 <sup>6)10)</sup>	0 <sup>6)</sup>			
			-2.9 <sup>7)</sup>	11.0 <sup>7)</sup>	0 <sup>7)10)</sup>	13 <sup>7)</sup>			
			-3.1 <sup>8)</sup>	3.1 <sup>8)</sup>	8 <sup>7)10)</sup>	–			

1) AN on request

5) Gain State: G3

8) Gain state: G6

2) Gain state: G0

6) Gain G4

9) Gain state: Bypass

3) Gain state: G1

7) Gain state: G5

10) Based on preliminary datasheet

4) Gain state: G2

Please visit <https://www.infineon.com/cms/en/product/rf-wireless-control/low-noise-amplifier-lna-ics/lte-3g-lnas/> for alternative devices.

## 2.4 Switch + LNA modules

The Switch + LNA module consists of a SPxT switch and a broadband LNA. It is able to support as many individual bands for single-carrier operation as well as carrier aggregation mode. It improves receiver performance significantly by reducing the noise from the long route line between the antenna and the transceiver, and by compensating for the losses incurred due to the band pass filter and NF of the transceiver. All devices are programmable using RFFE MIPI.

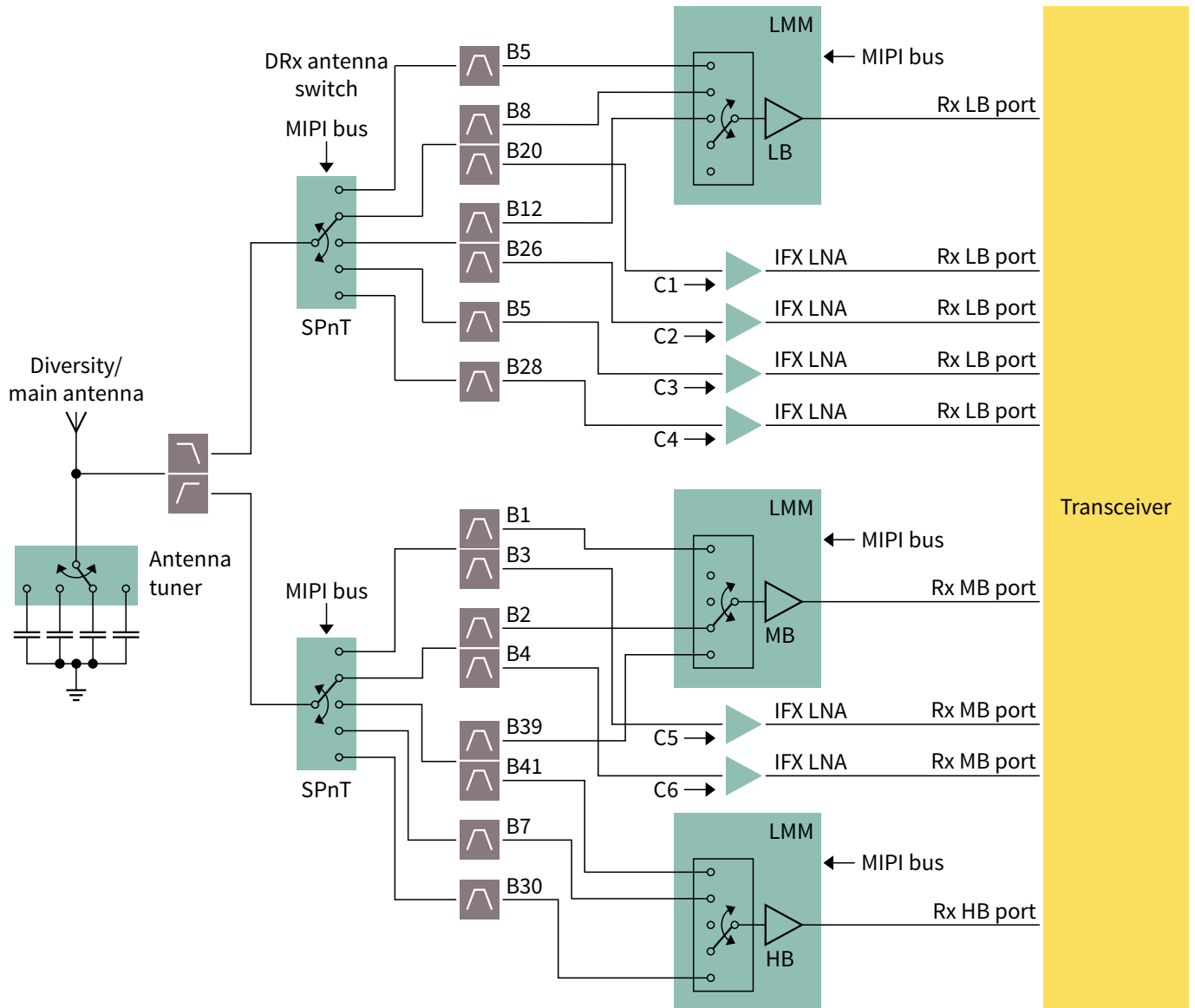

Figure 9 Switch + LNA module implemented in the diversity path

### Switch + LNA modules for LTE-advanced applications

Product	Description	App. note	Freq. Range [MHz]	Gain [dB]	NF [dB]	IP <sub>-1dB</sub> [dBm]	IIP <sub>3</sub> [dBm]	Supply V <sub>DD</sub> [V]	Current [mA]	Package
<a href="#">BGM12LBA9</a> <sup>3)</sup>	SPDT+LNA	on request	703–960	13.3 / -3.2	0.85 / 3.2	-5	+3 / +17	1.6...3.1	5.2 <sup>2)</sup>	ATSLP-9
<a href="#">BGM14HBA12</a> <sup>3)</sup>	SP4T+LNA	on request	1800–2700	18.0 / -4.0	0.8 / 4.5	-17	-3 / +21	1.65...3.3	5.0 <sup>2)</sup>	ATSLP-12
<a href="#">BGM13HBA9</a> <sup>3)</sup>	SP3T+LNA	on request	1805–2690	15.0 / -5.3	0.9 / 5.3	-12	-2 / +20	1.6...3.1	5.1 <sup>2)</sup>	ATSLP-9
<a href="#">BGM15LA12</a> <sup>1) 3)</sup>	SP5T+LNA	AN373 <sup>1)</sup>	700–1000	15.0	1.1	-2.5	6	2.2...3.3	4.8 <sup>2)</sup>	ATSLP-12

1) On request

3) High Gain / Bypass Mode

2) High Gain Mode

## 2.5 RF FE Devices for 3.5 GHz TD-LTE

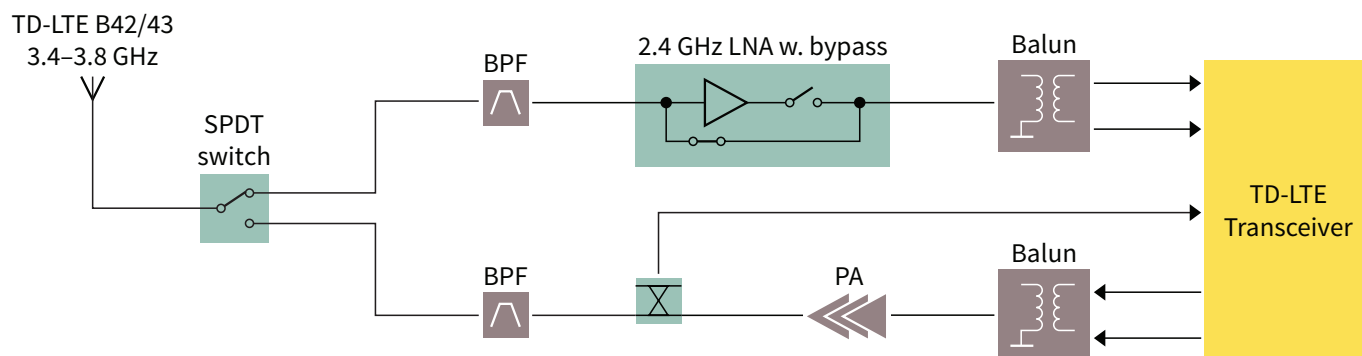

Figure 10 Block diagram for 3.5 GHz TD-LTE RF MMIC LNAs

Product	App. note	Gain [dB]	NF [dB]	IP <sub>-1dB</sub> [dBm]	IIP <sub>3</sub> [dBm]	Supply V <sub>DD</sub> [V]	Current [mA]	Package
<a href="#">BGA8V1BN6</a>	on request	15.0/-5.3	1.2 / 5.3	-15 / -3	-3 / +6	1.6...3.1	4.2 / 0.2	TSNP-6
BGAV1A10 <sup>1)</sup>	on request	18.0 <sup>2)</sup>	1.3 <sup>2)</sup>	-13 <sup>2)</sup>	-3 <sup>2)</sup>	1.7...1.9	5.0 / 0.07	ATSLP-10
		15.3 <sup>3)</sup>	1.4 <sup>3)</sup>	-13 <sup>3)</sup>	-3 <sup>3)</sup>			
		8.9 <sup>4)</sup>	1.5 <sup>4)</sup>	-6 <sup>4)</sup>	+1 <sup>4)</sup>			
		-0.7 <sup>5)</sup>	10.1 <sup>5)</sup>	+3 <sup>5)</sup>	+9 <sup>5)</sup>			
		-3.9 <sup>6)</sup>	3.9 <sup>6)</sup>		+32 <sup>6)</sup>			
BGA9V1MN9	on request	21.0 <sup>2)</sup>	0.75 <sup>2)</sup>	-18 <sup>2)</sup>	-6 <sup>2)</sup>	1.1...2	3.5 / 2.0	TSNP-9
		18.0 <sup>3)</sup>	0.8 <sup>3)</sup>	-17 <sup>3)</sup>	-3 <sup>3)</sup>			
		14.9 <sup>4)</sup>	1.0 <sup>4)</sup>	-16 <sup>4)</sup>	-3 <sup>4)</sup>			
		11.9 <sup>5)</sup>	1.15 <sup>5)</sup>	-16 <sup>5)</sup>	-3 <sup>5)</sup>			
		8.5 <sup>6)</sup>	1.4 <sup>6)</sup>	-16 <sup>6)</sup>	-3 <sup>6)</sup>			
		-2.7 <sup>7)</sup>	11 <sup>7)</sup>	1 <sup>7)</sup>	8 <sup>7)</sup>			
		3.08 <sup>7)</sup>						
<a href="#">BGB707L7ESD</a>	TR171 <sup>1)</sup>	14.3	1.3	-8	-5	2.8	5.4	TSLP-7-1

1) On request

2) Gain State: G0

3) Gain State: G1

4) Gain State: G2

5) Gain State: G3

6) Gain State: Bypass

7) Based on preliminary datasheet

### RF CMOS TX/RX switches

Product	Type	App. note	Supply V <sub>DD</sub> [V]	V <sub>str1</sub> <sup>1)</sup> [V]	IL <sup>2)</sup> [dB]	Isolation [dB]	P <sub>in,max</sub> <sup>3)</sup> [dBm]	Control Interface	Package
<a href="#">BGS12P2L6</a>	SPDT	on request	1.65...3.4	1.35...V <sub>DD</sub>	0.20 / 0.25	45 / 39	37	GPIO	TSLP-6

1) Digital control voltage

3) Maximum input power

2) IL = Insertion Loss

Please visit <https://www.infineon.com/cms/en/product/rf-wireless-control/low-noise-amplifier-lna-ics/lte-3g-lnas/> for alternative devices.



### 3 Global Navigation Satellite Systems

Global Navigation Satellite Systems (GNSSs) are among the most available applications in personal navigation devices, smart phones, wearable devices as well as vehicles. Several GNSS systems are in operation globally, such as GPS, Glonass, Galileo, BeiDou, IRNSS and QZSS.

The GNSS satellite signals transmit at an extremely low power level of about -130 dBm. High power jammer signals may leak into the GNSS receiver and affect the receiver's sensitivity by overdriving the receiver's LNA. This presents a major challenge to RF FE designers to maintain the receiver's

sensitivity to weak incoming GNSS signals. Benefiting from our long years of RF design expertise, application know-how and proven product quality, Infineon offers GNSS LNAs with the following highlights:

- › Extremely low noise figure
- › Various levels of gain catering different technical needs
- › High Linearity against out-of-band jammer signals, application circuits offering notch rejection filters
- › Current consumption down to 1 mA combined with the capability of supporting 1.2 V for next generation low power RF platforms

### 3.1 GNSS-enabled smart phones and wearable devices

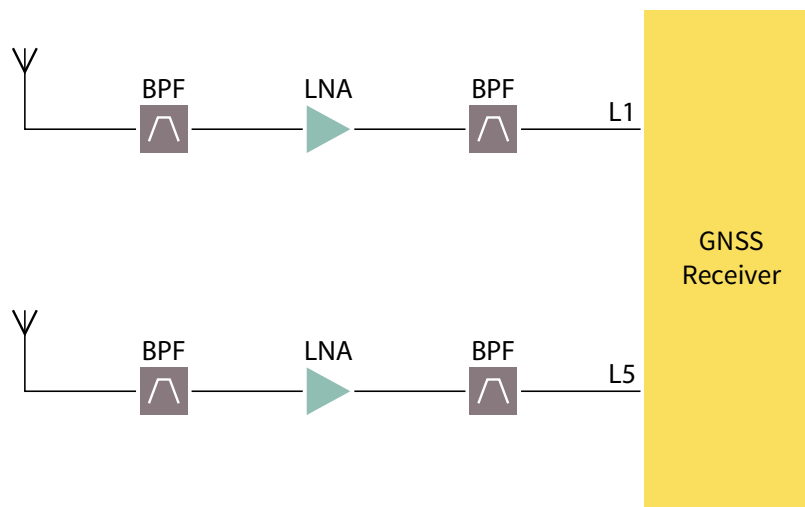

Figure 11 GNSS RF frontend for smart phones and wearable devices

#### RF MMIC LNAs for GNSS L1 band

Product	App. note	Gain <sup>1)</sup> [dB]	NF <sup>1)</sup> [dB]	IP <sub>-1dB</sub> <sup>1)</sup> [dBm]	Oob_IIP <sub>3</sub> <sup>2)</sup> [dBm]	Supply V <sub>DD</sub> [V]	Current <sup>1)</sup> [mA]	Package
<a href="#">BGA123L4</a>	<a href="#">AN551</a> <a href="#">AN578</a> <sup>4)</sup>	18.3 18.0	0.75 0.9	-15 -14	-7 -9	1.1...3.3	1.1 1.1	TSLP-4-11
<b>NEW</b> <a href="#">BGA123N6</a>	AN626 AN628 <sup>4)</sup>	18.8	0.75	-15	-10	1.1...3.3	1.35	TSNP-6-2
<a href="#">BGA524N6</a>	<a href="#">AN400</a> <a href="#">AN575</a> <sup>4)</sup>	19.6 19.1	0.65 0.95	-12 -15	-6 -4	1.5...3.3	2.5 2.5	TSNP-6-2
<a href="#">BGA824N6</a>	<a href="#">AN325</a> <a href="#">AN334</a> <sup>4)</sup> <a href="#">AN618</a> <sup>5)</sup>	17.0 16.4 16.5	0.65 0.9 1.1	-7 -9 -10	8 7 7	1.5...3.3	3.9 4.0 4.0	TSNP-6-2
<a href="#">BGA855N6</a>	AN596 <sup>3)</sup>	17.0	0.75	-16	4	1.5...3.3	4.8	TSNP-6-2

1) Supply voltage at 1.8 V, with 0402 LQW inductor for matching

2) Input frequency at 1712.7 MHz, 1850 MHz; P<sub>in</sub> = -20 dBm; measured at 1575.4 MHz

3) Retuned with additional output matching solutions

4) Band rejection LTE band 13

5) Band rejection N77 – N79 bands

#### RF MMIC LNAs for GNSS L2 band / L5 band

Product	App. note	Gain <sup>1)</sup> [dB]	NF <sup>1)</sup> [dB]	IP <sub>-1dB</sub> <sup>1)</sup> [dBm]	Oob_IIP <sub>3</sub> <sup>2)</sup> [dBm]	Supply V <sub>DD</sub> [V]	Current <sup>1)</sup> [mA]	Package
<a href="#">BGA123L4</a>	<a href="#">AN572</a> <sup>3)</sup>	16.2	0.85	-19	-12	1.1...3.3	1.1	TSLP-4-11
<b>NEW</b> <a href="#">BGA125N6</a>	AN627	19.9	0.8	-14	3	1.1...3.3	1.35	TSNP-6-2
<a href="#">BGA524N6</a>	AN418 <sup>3)</sup> <a href="#">AN537</a> <sup>3)</sup>	17.8 18.2	0.8 0.75	-14 -15	- -	1.5...3.3	2.5 2.5	TSNP-6-2
<a href="#">BGA824N6</a>	<a href="#">AN542</a> <sup>3)</sup>	17.5	0.75	-12	6	1.5...3.3	4.1	TSNP-6-2
<a href="#">BGA855N6</a>	AN580 AN601 AN619 <sup>4)</sup>	18.0 16.8 <sup>4)</sup>	0.65 1.2 <sup>4)</sup>	-12 -17 <sup>4)</sup>	5 17 <sup>4)</sup>	1.5...3.3	5.0 5.0 5.0	TSNP-6-2

1) Supply voltage at 1.8 V, with 0402 LQW inductor for matching

2) Input frequency at 1850 MHz, 2500 MHz; P<sub>in</sub> = -25 dBm, measured at 1200 MHz

3) Retuned with additional output matching solutions

4) Band rejection N77 – N79 bands

For antenna protection solutions, please refer to chapter [“Interface protection against ESD/Surge”](#).

### 3.2 GNSS-enabled active antenna modules

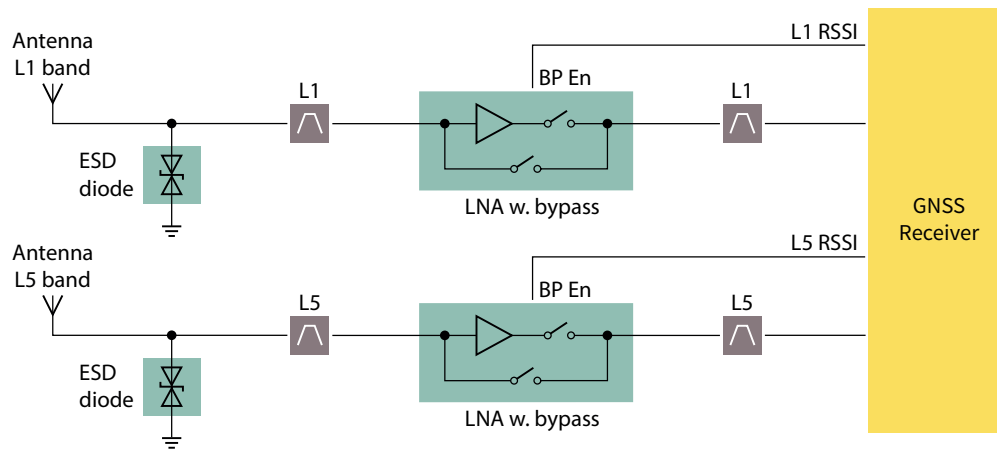

Figure 12 GNSS RF frontend with bypass LNAs for active antenna modules

#### RF MMIC LNAs for GNSS L1 band

Product	App. note	Gain <sup>1)</sup> [dB]	NF <sup>1)</sup> [dB]	IP <sub>-1dB</sub> <sup>1)</sup> [dBm]	IIP <sub>3</sub> <sup>2)</sup> [dBm]	Supply V <sub>DD</sub> [V]	Current <sup>1)</sup> [mA]	Package
<a href="#">BGA5L1BN6</a>	on request	17.0	0.85	-15	-	1.5...3.3	8.5 / 0.09	TSNP-6-2
<a href="#">BGA5M1BN6</a>	<a href="#">AN612</a> <sup>4)</sup>	17.5 / -4.0	0.85 / 5.0	-20 / 4	-6 / 4 <sup>2)</sup>	1.5...3.3	9.5 / 0.09	TSNP-6-2
<a href="#">BGB707L7ESD</a> <sup>5)</sup>	<a href="#">AN_1805_PL32</a>	19.9	0.99	-13.4	-0.83 <sup>3)</sup>	3	11.9	TSLP-7-1
<a href="#">BGB741L7ESD</a> <sup>5)</sup>	<a href="#">1806_113119</a> <sup>4)</sup>	19.2	1.14	-6.2	5.73	3	9.3	TSLP-7-1

- 1) Supply voltage at 1.8 V, with 0402 LQW inductor for matching
- 2) Out-of-band IIP<sub>3</sub>: input frequency at 1712.7 MHz, 1850 MHz; P<sub>in</sub> = -20 dBm; measured at 1575.4 MHz
- 3) P<sub>in</sub> = -30 dBm per tone, f<sub>1</sub> = 1575 MHz and f<sub>2</sub> = 1576 MHz
- 4) Retuned with additional matching components
- 5) Without bypass functions

#### RF MMIC LNAs for GNSS L2 band / L5 band

Product	App. note	Gain <sup>1)</sup> [dB]	NF <sup>1)</sup> [dB]	IP <sub>-1dB</sub> <sup>1)</sup> [dBm]	IIP <sub>3</sub> <sup>2)</sup> [dBm]	Supply V <sub>DD</sub> [V]	Current <sup>1)</sup> [mA]	Package
<a href="#">BGA5L1BN6</a>	on request	16.3 / -2.0	0.9 / 5.0	-14 / 1	-	1.5...3.3	8.5 / 0.09	TSNP-6-2
<a href="#">BGA5M1BN6</a>	<a href="#">AN611</a> <sup>4)</sup>	16.0 / -4.0	1.0 / 5.0	-19 / -1	-9 <sup>2)</sup>	1.5...3.3	9.5 / 0.09	TSNP-6-2
<a href="#">BGB707L7ESD</a> <sup>5)</sup>	<a href="#">AN_1805_PL32</a> <a href="#">1806_113119</a> <sup>4)</sup>	20.5	1.03	-13.9	-1.3 <sup>3)</sup>	3	11.9	TSLP-7-1
<a href="#">BGB741L7ESD</a> <sup>5)</sup>		19.7	1.16	-6.5	5.1 <sup>3)</sup>	3	9.3	TSLP-7-1
<a href="#">BGB707L7ESD</a> <sup>5)</sup>		20.5	1.01	-14.1	-2.6 <sup>3)</sup>	3	11.9	TSLP-7-1
<a href="#">BGB741L7ESD</a> <sup>5)</sup>		19.6	1.16	-6.6	1.9 <sup>3)</sup>	3	9.3	TSLP-7-1

- 1) Supply voltage at 1.8 V, with 0402 LQW inductor for matching
- 2) Out-of-band IIP<sub>3</sub>: input frequency at 1712.7 MHz, 1850 MHz; P<sub>in</sub> = -20 dBm; measured at 1575.4 MHz
- 3) P<sub>in</sub> = -30 dBm per tone, f<sub>1</sub> = 1575 MHz and f<sub>2</sub> = 1576 MHz
- 4) Retuned with additional matching components
- 5) Without bypass functions

#### RF transistor LNAs for GNSS L1 band (without bypass functions)

Product	App. note	Frequency [MHz]	Gain <sup>1)</sup> [dB]	NF <sup>1)</sup> [dB]	IP <sub>-1dB</sub> <sup>1)</sup> [dBm]	IIP <sub>3</sub> <sup>2)</sup> [dBm]	Supply V <sub>DD</sub> [V]	Current [mA]	Package
<a href="#">BFP640ESD</a>	<a href="#">AN_1805_PL32</a> <a href="#">1806_113119</a>	1575	17.8	0.82	-17.1	2.7	3	8.0	SOT343
<a href="#">BFP740</a>			19.1	0.71	-16.4	2.6	3	9.8	SOT343
<a href="#">BFP740ESD</a>			18.5	0.72	-18.1	0.8	3	9.4	SOT343
<a href="#">BFP842ESD</a>			17.9	0.66	-13.0	2.7	3	10.9	SOT343
<a href="#">BFP640FESD</a>			18.3	0.81	-17.9	1.1	3	8.0	TSFP-4-1
<a href="#">BFP740F</a>			19.3	0.71	-17.6	1.2	3	9.4	TSFP-4-1
<a href="#">BFP740FESD</a>			19.8	0.68	-17.3	1.8	3	9.8	TSFP-4-1

- 1) Supply voltage at 3.0 V, with 0402 LQW inductor for matching
- 2) P<sub>in</sub> = -30 dBm per tone, f<sub>1</sub> = 1575 MHz and f<sub>2</sub> = 1576 MHz

# 4 Wireless-LAN, Unlicensed LTE (LTE-U) and Licensed Assisted Access (LAA)

## 4.1 Wireless-LAN routers and access points

The Wireless-LAN (WLAN) function is one of the most important connectivity functions between WLAN access points and smartphones, tablets, and laptops. Key performance metrics for the WLAN application are data transfer speed and coverage, which are greatly influenced by transmitted power, receiver sensitivity, noise and interference.

Infineon Technologies provides high-performance RF transistors and MMIC LNAs, which offer exceptionally low NF, high gain, and high linearity at low power consumption levels. The RF transistors are based on robust ultra-low-noise SiGe:C technologies, and their optimized inner transistor cell structure leads to best-in-class power gain and NF at high frequencies, including 2.4 GHz and 5 to 6 GHz frequency bands. Besides, Infineon also provides RF CMOS Switches and PIN diodes for WLAN applications.

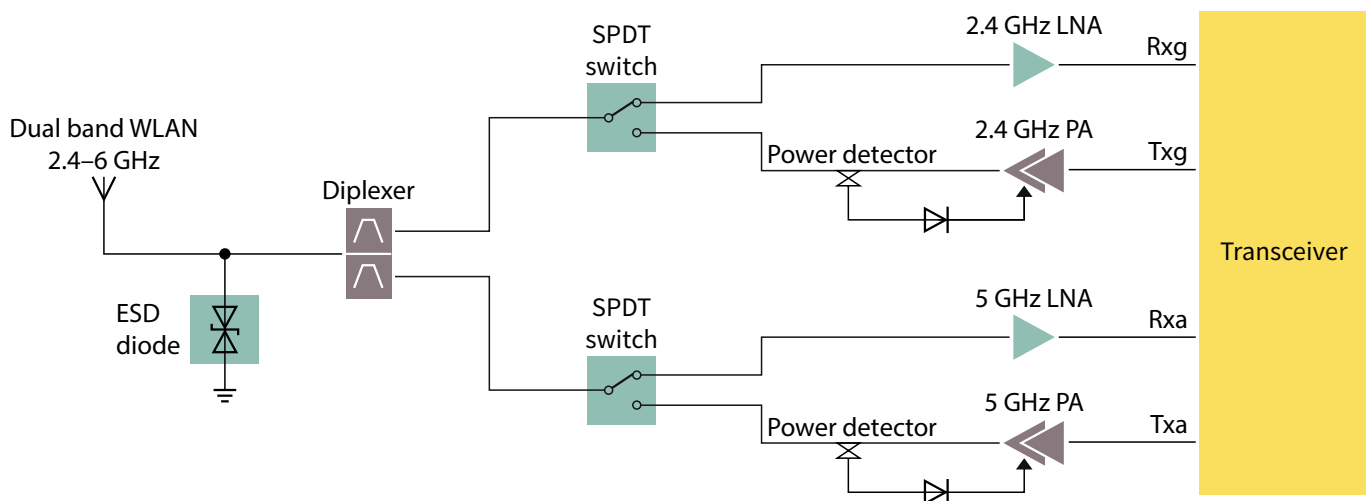

Figure 13 Dual-band (2.4/5.0 GHz) WLAN (IEEE 802.11a/b/g/n) frontend

### RF transistor LNAs

Product	App. note	Frequency [MHz]	Gain [dB]	NF [dB]	OP <sub>-1dB</sub> [dBm]	OIP <sub>3</sub> <sup>1)</sup> [dBm]	Supply V <sub>DD</sub> [V]	Current [mA]	Package
<b>2.4 GHz LNA</b>									
<a href="#">BFP740</a>	<a href="#">AN_1805_PL32_1806_111452</a>	2450	18.9	0.81	5.2	12.6	3	13.5	SOT343
<a href="#">BFP740ESD</a>		2450	18.8	0.76	5.0	12.9	3	13.5	SOT343
<a href="#">BFP760</a>		2450	16.6	0.82	6.6	17.5	3	16.6	SOT343
<a href="#">BFP842ESD</a>		2450	18.5	0.76	8.9	22.3	3	8.6	SOT343
<a href="#">BFP740F</a>		2450	17.1	0.71	2.1	11.1	3	11.6	TSFP-4-1
<a href="#">BFP740FESD</a>		2450	16.6	0.76	1.5	10.7	3	11.0	TSFP-4-1
<a href="#">BFR840L3RHESD</a>		2450	18.5	1.02	0.6	11.4	3	11.4	TSLP-3-9
<a href="#">BGB707L7ESD</a>		2450	15.6	1.2	6.3	10.3	3	6.0	TSLP-7-1

1) P<sub>in</sub> = -25 dBm per tone and Tone spacing: 1 MHz

2) Please visit [www.infineon.com/lna](http://www.infineon.com/lna) up to 12 GHz for alternative devices

## RF transistor LNAs (cont'd)

Product	App. note	Frequency [MHz]	Gain [dB]	NF [dB]	OP <sub>-1dB</sub> [dBm]	OIP <sub>3</sub> <sup>1)</sup> [dBm]	Supply V <sub>DD</sub> [V]	Current [mA]	Package
<b>5 GHz LNA</b>									
<a href="#">BFP840ESD</a>	<a href="#">AN_1805_PL32_1806_111452</a>	5100	16.3	1.07	4.9	16.4	3	10.3	SOT343
		5900	15.3	1.04					
<a href="#">BFP840FESD</a>		5100	19.2	1.01	7.4	18.6	3	14.3	TSFP-4-1
		5900	18.0	1.02					
<a href="#">BFR840L3RHESD</a>		5100	15.0	0.99	4.9	16.4	3	9.2	TSLP-3-9
		5900	14.1	0.98					

1) P<sub>in</sub> = -25 dBm per tone and Tone spacing: 1 MHz

2) Please visit [www.infineon.com/lna](http://www.infineon.com/lna) up to 12 GHz for alternative devices

## RF MMIC LNAs

Product	App. note	Gain [dB]	NF [dB]	IP <sub>-1dB</sub> [dBm]	IIP <sub>3</sub> [dBm]	Supply V <sub>DD</sub> [V]	Current [mA]	Package
<b>2.4 GHz LNA</b>								
<a href="#">BGA7H1BN6</a>	-	12.3 / -3.1	0.9 / 2.7	-1 / +5	+5 / +16	1.5...3.3	4.3 / 0.09	TSNP-6-2
<a href="#">BGA7H1N6</a>	<a href="#">AN365</a>	13.0	0.7	2	5	1.5...3.6	4.9	TSNP-6-2
<a href="#">BGB741L7ESD</a>	on request	17.5 18.7	1.5 1.1	-4.0 -6.7	-1.2 +2.0	3.0	10.0 10.8	TSLP-7-1
<b>5 GHz LNA</b>								
<a href="#">BGB741L7ESD</a>	on request	12	2.0	-1	8.5	3.0	6.0	TSLP-7-1
<a href="#">BGB707L7ESD</a>	on request	13.3	2.3	-6	-4.3	2.8	3.2	TSLP-7-1

## RF CMOS switches

Product	Type	App. note	Supply V <sub>DD</sub> [V]	V <sub>ctrl</sub> <sup>1)</sup> [V]	IL <sup>2)</sup> [dB]	Isolation <sup>3)</sup> [dB]	P <sub>in,max</sub> <sup>4)</sup> [dBm]	Control Interface	Package
<b>NEW</b> <a href="#">BGS12WN6</a>	SPDT	on request	1.65...3.6	1.35...V <sub>DD</sub>	0.16 / 0.19	46 / 39	26	GPIO	TSNP-6
<b>NEW</b> <a href="#">BGS14WMA9</a>	SP4T	on request	1.65...1.95	RFFE MIPI	0.22 / 0.27	46 / 39	26	RFFE MIPI	ATSLP-9

1) Digital Control Voltage (logic high)

3) Isolation at 1.0/ 2.0 GHz from RF<sub>in</sub> to RF port

2) IL = Insertion Loss at 1.0/ 2.0 GHz

4) Maximum input power

## RF PIN diodes

Product	App. note	r <sub>F</sub> <sup>1)</sup> [Ω]	@I <sub>F</sub> [mA]	r <sub>F</sub> <sup>1)</sup> [Ω]	@I <sub>F</sub> [mA]	C <sub>T</sub> <sup>2)</sup> [pF]	@V <sub>R</sub> [V]	CC <sub>L</sub> <sup>3)</sup> [ns]	Package
<a href="#">BAR90-02EL</a> <a href="#">BAR90-02ELS</a>	-	1.3	3	0.8	10	0.25	1	750	TSLP-2-19 TSSLP-2-3
<a href="#">BAR64-02EL</a>	-	12.5	1	2.1	10	0.23	20	1550	TSLP-2-19
<a href="#">BAR64-04</a> <a href="#">BAR64-05</a> <a href="#">BAR64-06</a>	-	12.5	1	2.1	10	0.23	20	1550	SOT23
<a href="#">BAR64-04W</a> <a href="#">BAR64-05W</a> <a href="#">BAR64-06W</a>	-	12.5	1	2.1	10	0.23	20	1550	SOT323

1) At 100 MHz

2) At 1 MHz

3) The charge carrier life time between the forward bias of I<sub>F</sub> = 10 mA and reverse bias of I<sub>R</sub> = 6 or 3 mA

For antenna protection with TVS diodes, please refer to chapter [“Interface protection against ESD/Surge”](#).

## 4.2 Unlicensed LTE (LTE-U) and Licensed Assisted Access (LAA)

Unlicensed Long-Term Evolution (LTE-U) and Licensed Assisted Access (LAA) are new concepts to increase the available RF bandwidth of mobile users to achieve much higher data rates than are possible with common LTE bands. LTE-U and LAA make use of the 5- to 6-GHz Industrial, Science and Medicine (ISM) bands and easily make use a bandwidth of up to 160 MHz with a simple RF FE. The additionally available bandwidth can be combined with the common LTE

bands at lower frequencies. In order to avoid link collision between WLAN and LTE-U or LAA, various methods have been defined by the 3rd Generation Partnership Project (3GPP).

Below Figure shows how LAA and LTE-U solutions work together with the LTE FDD operation by using carrier aggregation or link aggregation.

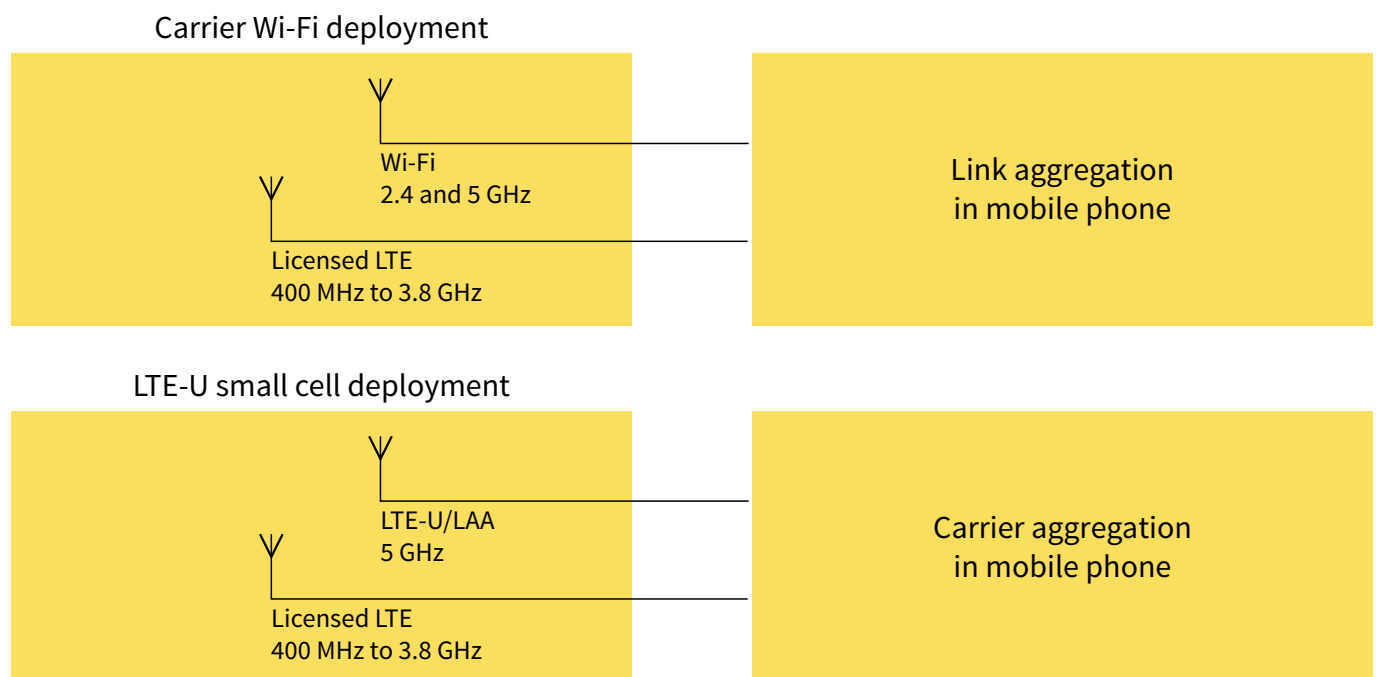

Figure 14 LTE FDD operation supported by LAA and LTE-U techniques using link aggregation or CA



Figure 15 shows one of the first proposals in 3GPP for a 5-GHz LAA downlink to support common FDD up-/downlinks.

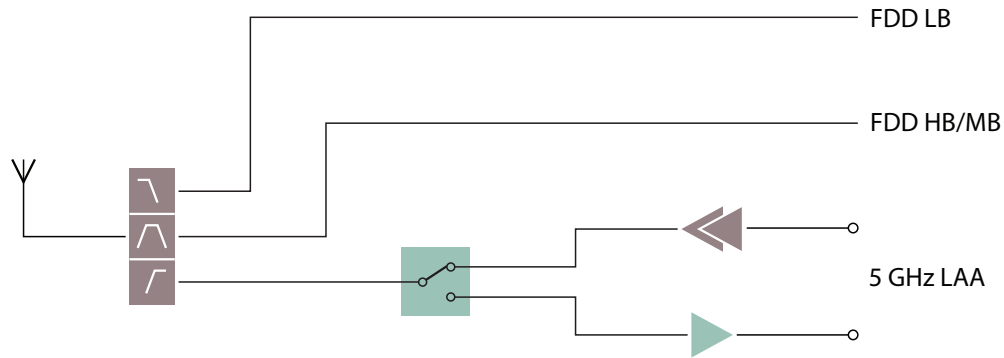

Figure 15 Block diagram of a 5 GHz LAA to support common FDD operation using CA

### RF MMIC LNAs

Product	App. note	Gain [dB]	NF [dB]	IP <sub>-1dB</sub> [dBm]	IIP <sub>3</sub> [dBm]	Supply V <sub>DD</sub> [V]	Current [mA]	Package
<a href="#">BGAU1A10<sup>1)</sup></a>	on request	20.5/.../9.0/.../-6.5	1.7/.../1.6/.../6.5	-18/.../-6/.../3	-8/.../-2/.../+30	1.6...1.9	5.0/0.1	ATSLP-10
<a href="#">BGA8U1BN6</a>	on request	14.0 / -5.0	1.6 / 5.0	-15 / -5	-3 / +11	1.6...3.1	4.0/0.2	TSNP-6
<b>NEW</b> <a href="#">BGA9C1MN9</a>	on request	19.0/.../9.6/.../-3.1	0.9/.../1.45/.../3.1	-17/.../-12/.../8	-5/.../0/.../13	1.1...2.0	3.5/0.002	TSNP-9
<a href="#">BGB741L7ESD</a>	on request	12.0	2.0	-1	8.5	3.0	6.0	TSLP-7-1
<a href="#">BGB707L7ESD</a>	on request	13.3	2.3	-6	-4.3	2.8	3.2	TSLP-7-1

1) On request

### RF CMOS switches

Product	Type	App. note	Supply V <sub>DD</sub> [V]	V <sub>ctrl</sub> <sup>1)</sup> [V]	IL <sup>2)</sup> [dB]	Isolation <sup>3)</sup> [dB]	P <sub>in,max</sub> <sup>4)</sup> [dBm]	Control Interface	Package
<b>NEW</b> <a href="#">BGS12WN6</a>	SPDT	on request	1.65...3.6	1.35...V <sub>DD</sub>	0.16 / 0.19	46 / 39	26	GPIO	TSNP-6
<b>NEW</b> <a href="#">BGS14WMA9</a>	SP4T	on request	1.65...1.95	RFFE MIPI	0.22 / 0.27	46 / 39	26	RFFE MIPI	ATSLP-9

- 1) Digital Control Voltage (logic high)
- 2) IL = Insertion Loss at 1.0/ 2.0 GHz
- 3) Isolation at 1.0/ 2.0 GHz from RF<sub>in</sub> to RF port
- 4) Maximum input power

### RF Schottky diodes for power detectors

Product	App. note	C <sub>T</sub> <sup>2)</sup> [pF]	@V <sub>R</sub> [V]	V <sub>F</sub> [mV]	@I <sub>F</sub> [mA]	V <sub>F</sub> [mV]	@I <sub>F</sub> [mA]	I <sub>R</sub> [μA]	@V <sub>R</sub> [V]	Package
<a href="#">BAT62-02V</a>	<a href="#">AN185<sup>3)</sup></a>	0.35	0	580	2	-	-	< 10	40	SC79
<a href="#">BAT15-02EL</a> <a href="#">BAT15-02ELS</a>	on request	0.26	0	230	1	320	10	< 5	4	TSLP-2-19 TSSLP-2-3

- 1) D = Dual; T = Triple; Q = Quadruple
- 2) At 1 MHz
- 3) On request
- 4) Please visit <https://www.infineon.com/cms/en/product/rf-wireless-control/rf-diode/rf-mixer-and-detector-schottky-diode/>

Please visit <https://www.infineon.com/cms/en/product/rf-wireless-control/low-noise-amplifier-lna-ics/lte-3g-lnas/> for alternative devices.

For antenna protection with TVS diodes, please refer to chapter [“Interface protection against ESD/Surge”](#).

# 5 FM radio, SDARS and mobile TV

## 5.1 FM radio in mobile devices and cars

Frequency Modulation (FM) radio function is widely available. FM radio enabled active antennas can be present in all kinds of devices such as mobile phones, PDAs, portable FM radios, and active antennas, etc.

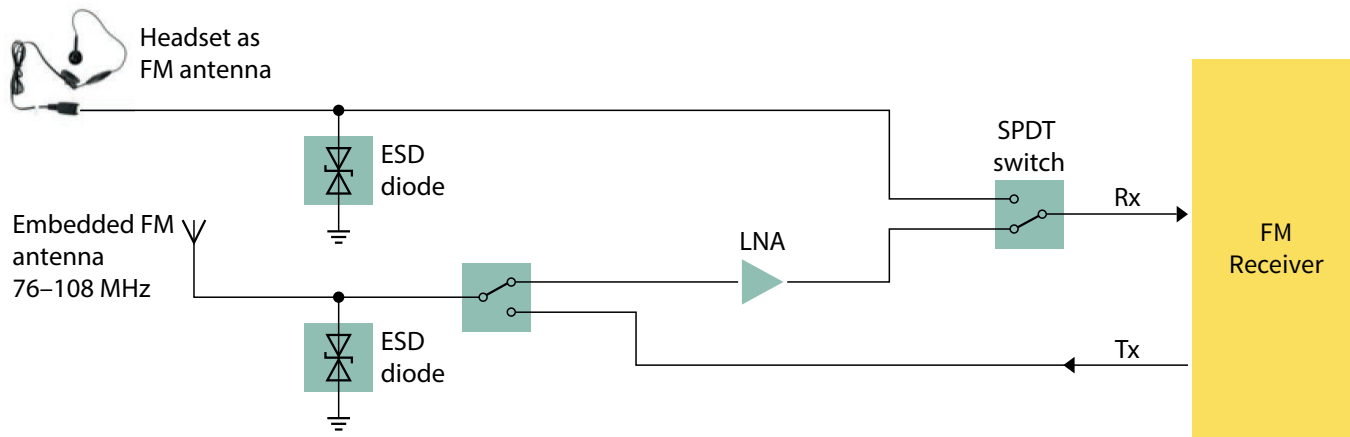

Figure 16 FM transmit/receive function block

### RF MMIC LNAs

Product	App. note	Gain <sup>2)</sup> [dB]	NF <sup>2)</sup> [dB]	IP <sub>-1dB</sub> <sup>2)</sup> [dBm]	IIP <sub>3</sub> <sup>2)</sup> [dBm]	Supply V <sub>DD</sub> [V]	Current <sup>2)</sup> [mA]	Package
<a href="#">BGA729N6</a>	<a href="#">AN441<sup>1)</sup></a> <a href="#">AN505<sup>1)</sup></a>	17.0 / -6.0	1.1 / 4.3	-15 / +5	-6.0 / +17.0	1.5...3.3	6.5 / 0.5	TSNP-6
<a href="#">BGB707LESD</a>	<a href="#">AN_1806_PL32_1808_171123</a>	18.3	1.15	-14	-9.2	2.8	4.0	TSLP-7-1

1) For 50-Ω antenna

2) Values in high-gain (HG) / low-gain (LG) mode

### RF transistor LNAs

Product	App. note	Frequency [MHz]	Gain [dB]	NF [dB]	OP <sub>-1dB</sub> [dBm]	OIP <sub>3</sub> <sup>1)</sup> [dBm]	Supply V <sub>DD</sub> [V]	Current [mA]	Package
<b>Matched to high impedance at the input</b>									
<a href="#">BFR340F</a>	<a href="#">AN_1806_PL32_1808_171123</a>	100	15.9	1.69	-13.7	1.5	1.8	3.3	TSFP-3
<a href="#">BFR460L3</a>		100	14.6	1.04	-15.5	-1.4	1.8	3.5	TSLP-3-1
<a href="#">BFP540ESD</a>		100	11.9	1.2	-18.6	-4.3	1.8	2.4	SOT343
<b>Matched to 50 Ω at the input</b>									
<a href="#">BFP460</a>	<a href="#">AN_1806_PL32_1808_171123</a>	100	15.2	1.41	-13	-0.8	1.8	3.1	SOT343
<a href="#">BFP460</a>		100	18.7	1.24	-8.7	2.4	2.6	4.6	SOT343
<a href="#">BFR340F</a>		100	16.2	1.86	-11.3	0.5	1.8	3	TSLP-3-9

### RF CMOS switches

Product	Type	App. note	Supply V <sub>DD</sub> [V]	V <sub>ctrl</sub> <sup>1)</sup> [V]	IL <sup>2)</sup> [dB]	Isolation <sup>3)</sup> [fF]	P <sub>in,max</sub> <sup>4)</sup> [V]	Control Interface	Package
<a href="#">BGS12WN6</a>	SPDT	on request	1.65...3.6	1.35...V <sub>DD</sub>	0.16 / 0.19	46 / 39	26	GPIO	TSNP-6
<a href="#">BGS12P2L6</a>	SPDT	on request	1.65...3.4	1.35...V <sub>DD</sub>	0.20 / 0.25	45 / 39	37	GPIO	TSLP-6

1) Digital Control Voltage (logic high)

2) IL = Insertion Loss at 1.0/ 2.0 GHz

3) Isolation at 1.0/ 2.0 GHz from RF<sub>in</sub> to RF port

4) Maximum input power

5) Please visit [www.infineon.com/rfswitches](http://www.infineon.com/rfswitches) for alternative devices

## 5.2 SDARS and HD radio

SDARS is a digitally encoded satellite radio broadcasting in the S-band from 2320 MHz – 2332.5 MHz and 2332.5 MHz – 2345 MHz. SDARS provides paying subscribers with over 175 channels of “MP3-quality” digital radio. A general topology for the SDARS active antenna is shown below.

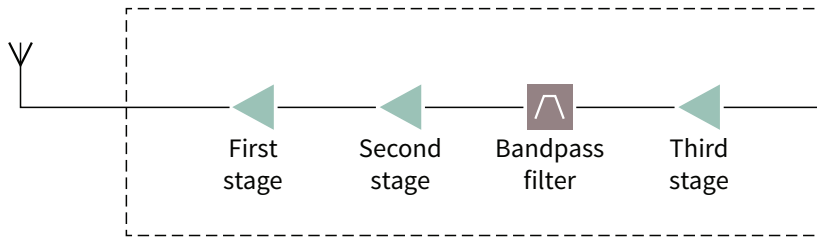

Figure 17 Block diagram example of the SDARS active antenna

### RF transistor & MMIC LNAs

Product	App. note	Frequency [MHz]	Gain [dB]	NF [dB]	OP <sub>-1dB</sub> [dBm]	OIP <sub>3</sub> <sup>(1)</sup> [dBm]	Supply V <sub>DD</sub> [V]	Current [mA]	Package
<b>First stage</b>									
<a href="#">BFP740F</a>	<a href="#">AN_1808_PL32_1810_120326</a>	2332.5	18.2	0.7	5.6	23.0	3.3	13	TSFP-4
<b>Second stage</b>									
<a href="#">BFP640ESD</a>	<a href="#">AN_1808_PL32_1810_120326</a>	2332.5	18.7	1.0	13.4	30.0	3.3	24	SOT343
<a href="#">BGA614</a>	on request	2332.5	17.5	2.1	12.0	25.0	2.4...5.0	40	SOT343
<b>Third stage</b>									
<a href="#">BGA614</a>	on request	2332.5	17.5	2.1	12.0	25.0	2.4...5.0	40	SOT343
<a href="#">BGA616</a>		2332.5	18.0	2.6	18.0	29.0	2.4...5.0	60	SOT343
<a href="#">BFP650</a>	<a href="#">AN_1808_PL32_1810_120326</a>	2332.5	14.2	1.2	17.3	34.0	3.3	57	SOT343
<a href="#">BFP450</a>		2332.5	10.3	2.6	17.8	32.7	3.3	88	SOT343

For antenna protection with TVS diodes, please refer to chapter [“Interface protection against ESD/Surge”](#).



### 5.3 TV reception in mobile devices

Mobile devices today have not only wireless functions for voice and data but also entertainment features. Mobile TV is one of the most fascinating features. It brings live news and entertainment programs onto the phone display and enables people not to miss their favorite programs. Product portfolios for mobile TV applications are described below.

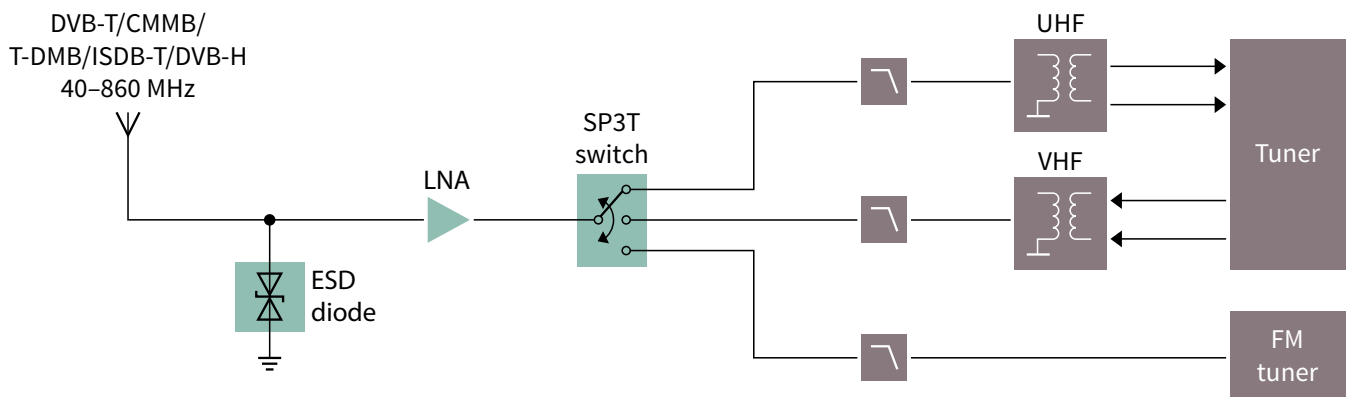

Figure 18 Block diagram of a FM/Mobile TV RF FE with band selection switch

#### RF MMIC LNAs

Product	App. note	Gain <sup>3)</sup> [dB]	NF <sup>3)</sup> [db]	IP <sub>-1dB</sub> <sup>3)</sup> [dBm]	IIP <sub>3</sub> <sup>3)</sup> [dBm]	Supply V <sub>DD</sub> [V]	Current <sup>3)</sup> [mA]	Package
<a href="#">BGA729N6</a>	<a href="#">AN441</a> <sup>2)</sup> <a href="#">AN505</a> <sup>2)</sup>	16.3 / -4.0	1.1 / 4.3	-15 / +5	-6 / +17	1.5...3.3	6.5 / 0.5	TSNP-6-2
<a href="#">BGB707L7ESD</a>	on request <sup>1)</sup>	13.0	1.5	-7	-11	3.0	2.9	TSLP-7-1

1) For high-ohmic antenna

2) For 50-Ω antenna

3) Values in high-gain (HG) / low-gain (LG) mode

5) Please visit [www.infineon.com/ltelna](http://www.infineon.com/ltelna) for alternative devices

#### RF CMOS switches

Product	Type	App. note	Supply V <sub>DD</sub> [V]	V <sub>ctrl</sub> <sup>1)</sup> [V]	IL <sup>2)</sup> [dB]	Isolation <sup>3)</sup> [dB]	P <sub>in,max</sub> <sup>4)</sup> [dBm]	Control Interface	Package
<a href="#">BGS13S4N9</a>	SP3T	on request	1.8...3.3	1.35...V <sub>DD</sub>	0.20 / 0.30	31 / 20	30	GPIO	TSNP-9

1) Digital Control Voltage (logic high)

2) IL = Insertion Loss at 1.0/ 2.0 GHz

3) Isolation at 1.0/ 2.0 GHz from RF<sub>in</sub> to RF port

4) Maximum input power

5) Please visit [www.infineon.com/rfswitches](http://www.infineon.com/rfswitches) for alternative devices

For antenna protection with TVS diodes, please refer to chapter [“Interface protection against ESD/Surge”](#).

## 6 Wearables and LiDAR

### 6.1 Wearables

Wearable devices have been increasingly popular thanks to their tiny weight, customized high-tec features, multiple wireless connectivity functions, and personalized outlooks. Typical examples are fitness trackers, smartwatches, smart footwears, etc.

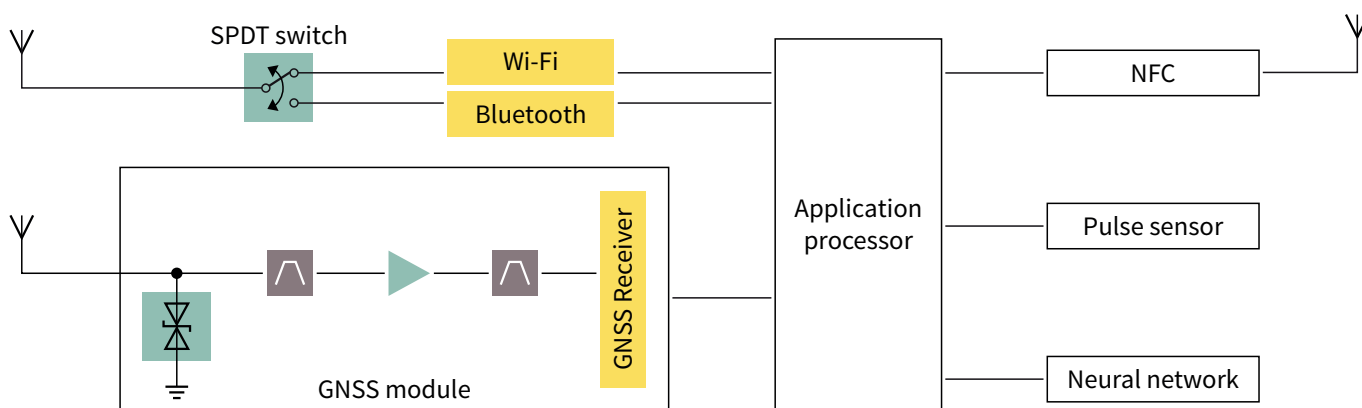

Figure 19 Block diagram of a smart watch

#### RF MMIC LNAs for GNSS L1 band

Product	App. note	Gain <sup>1)</sup> [dB]	NF <sup>1)</sup> [dB]	IP <sub>-1dB</sub> <sup>1)</sup> [dBm]	Oob_IIP <sub>3</sub> <sup>2)</sup> [dBm]	Supply V <sub>DD</sub> [V]	Current <sup>1)</sup> [mA]	Package
<a href="#">BGA123L4</a>	<a href="#">AN551</a> <a href="#">AN578</a> <sup>3)</sup>	18.3 18.0	0.75 0.9	-15 -14	-7 -9	1.1...3.3	1.1 1.1	TSLP-4-11
<b>NEW</b> <a href="#">BGA123N6</a>	AN626 AN628	18.8	0.75	-15	-10	1.1...3.3	1.35	TSNP-6-2
<a href="#">BGA524N6</a>	<a href="#">AN400</a> <a href="#">AN575</a> <sup>3)</sup>	19.6 19.1	0.65 0.95	-12 -15	-6 -4	1.5...3.3	2.5 2.5	TSNP-6-2

1) Supply voltage at 1.8 V, with 0402 LQW inductor for matching

3) Band rejection LTE band 13

2) Input frequency at 1712.7 MHz, 1850 MHz; P<sub>in</sub> = -20 dBm; measured at 1575.4 MHz

#### RF MMIC LNAs for GNSS L2 band / L5 band

Product	App. note	Gain <sup>1)</sup> [dB]	NF <sup>1)</sup> [dB]	IP <sub>-1dB</sub> <sup>1)</sup> [dBm]	Oob_IIP <sub>3</sub> <sup>2)</sup> [dBm]	Supply V <sub>DD</sub> [V]	Current <sup>1)</sup> [mA]	Package
<a href="#">BGA123L4</a>	<a href="#">AN572</a> <sup>3)</sup>	16.2	0.85	-19	-12	1.1...3.3	1.1	TSLP-4-11
<b>NEW</b> <a href="#">BGA125N6</a>	AN627	19.9	0.8	-14	3	1.1...3.3	1.35	TSNP-6-2
<a href="#">BGA524N6</a>	AN418 <sup>3)</sup> <a href="#">AN537</a> <sup>3)</sup>	17.8 18.2	0.8 0.75	-14 -15	- -	1.5...3.3	2.5 2.5	TSNP-6-2

1) Supply voltage at 1.8 V, with 0402 LQW inductor for matching

3) Retuned with additional output matching solutions

2) Input frequency at 1850 MHz, 2500 MHz; P<sub>in</sub> = -25 dBm, measured at 1200 MHz

4) Band rejection N77 - N79 bands

#### RF CMOS switches

Product	Type	App. note	Supply V <sub>DD</sub> [V]	V <sub>ctrl</sub> <sup>1)</sup> [V]	IL <sup>2)</sup> [dB]	Isolation <sup>3)</sup> [dB]	P <sub>in,max</sub> <sup>4)</sup> [dBm]	Control Interface	Package
<b>NEW</b> <a href="#">BGS12WN6</a>	SPDT	on request	1.65...3.6	1.35...V <sub>DD</sub>	0.16 / 0.19	46 / 39	26	GPIO	TSNP-6
<b>NEW</b> <a href="#">BGS14WMA9</a>	SP4T	on request	1.65...1.95	RFFE MIPI	0.22 / 0.27	46 / 39	26	RFFE MIPI	ATSLP-9

1) Digital Control Voltage (logic high)

3) Isolation at 1.0/ 2.0 GHz from RF<sub>in</sub> to RF port

5) Please visit [www.infineon.com/rfswitches](http://www.infineon.com/rfswitches)

2) IL = Insertion Loss at 1.0/ 2.0 GHz

4) Maximum input power

for alternative devices



## 6.2 LiDAR

LiDAR is a remote sensing technique that measures the distance to a target and creates a 3D map of the target object. Its versatility and high resolution make it suitable for application in guidance, rangefinders, etc. LiDAR uses different architectures as direct and indirect time-of-flight (ToF) measurements, or triangulation for detection and ranging.

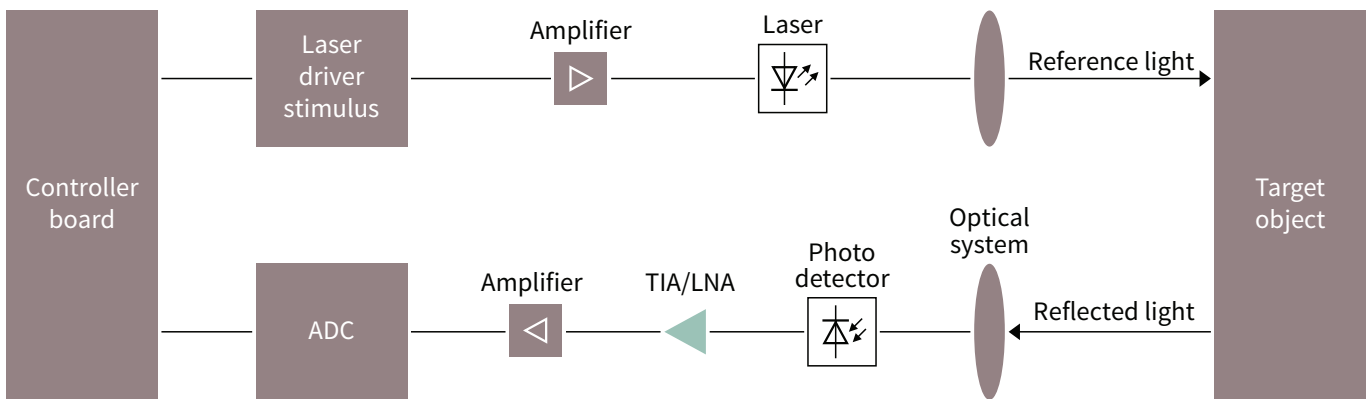

Figure 20 Block diagram example of the simplified LiDAR system

### RF transistor & MMIC LNAs

Product	App. note	3 dB Bandwidth [MHz]	Freq. [MHz]	Gain [dB]	NF [dB]	OP <sub>-1dB</sub> [dBm]	OIP <sub>3</sub> <sup>1)</sup> [dBm]	Supply V <sub>DD</sub> [V]	Current [mA]	Package
<a href="#">BFR740L3RH</a>	<a href="#">AN_1809_PL32_1811_161136</a>	0.0028–450	10	22.2	1	0.4	9.2	3.3	13.0	TSLP-3-9
			200	21.8	1	0	7.3			
			400	20.6	1	0.2	5.6			
<a href="#">BGA729N6</a>	on request	-	200	17.0	1	-2.0	12	1.5...3.3	6.5 / 0.5	TSNP-6-2
			400	16.5	1	0	12			

Note: 1) P<sub>in</sub> = -35 dBm per tone and tone spacing: 1 MHz

## 7 Interface protection against ESD/Surge

Infinion ESD protection devices improve ESD immunity at the system level by providing first-class protection beyond the IEC61000-4-2 level-4 standard, and offer:

- > Superior multi-strike absorption capability
- > Safe and stable clamping voltages to protect even the most sensitive electronic equipment
- > Full compliance with high-speed signal quality requirements
- > Efficient PCB space usage thanks to small 0201 and 01005 package dimensions
- > Extremely low leakage currents to extend battery life

In a mobile device, there are a lot of open access points such as charging port, microphones and buttons that could permit ESD strikes to reach the inner PCB. Often the point of entrance for an ESD strike is not obvious.

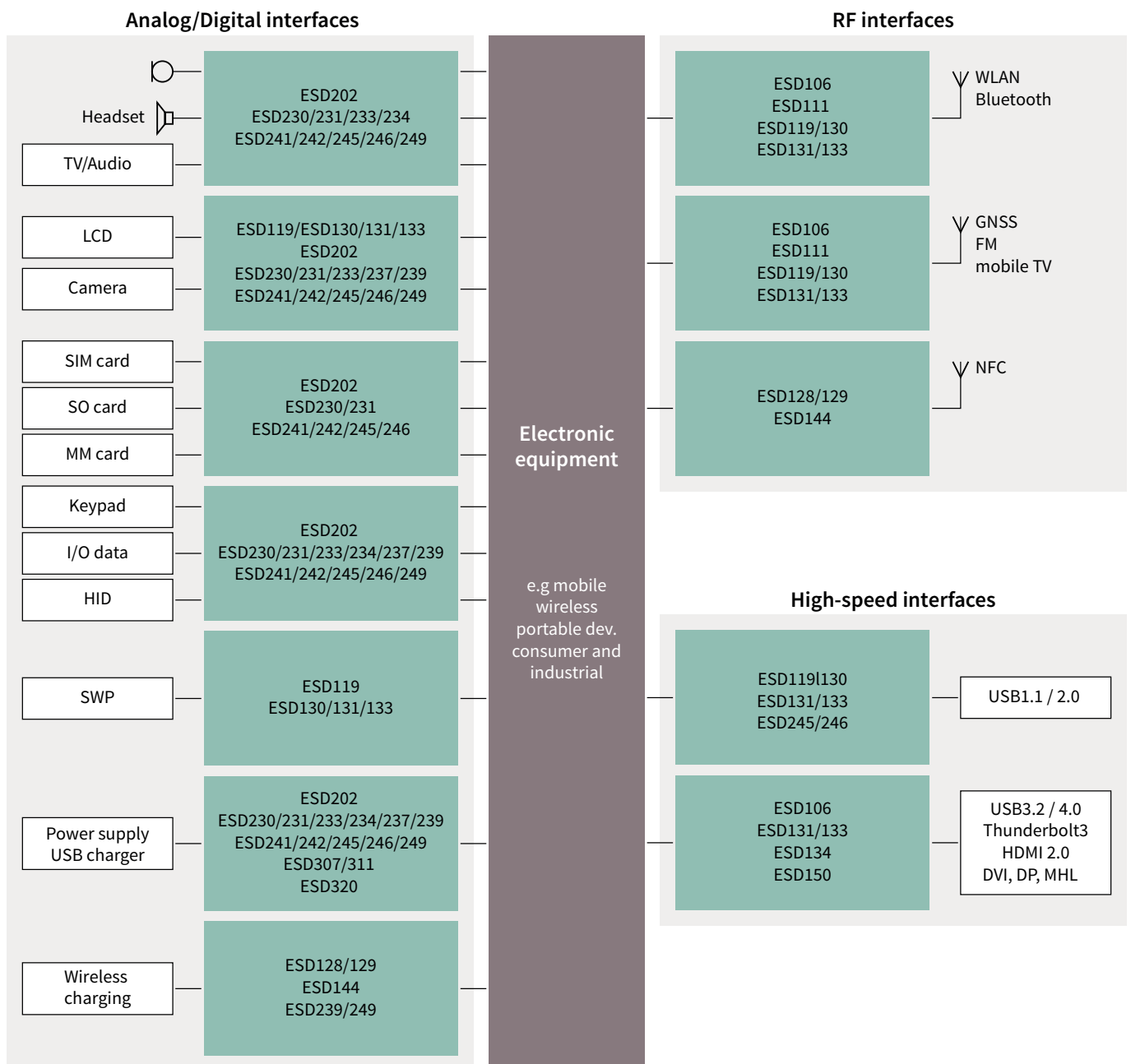

Figure 21 Interface protection with discrete ESD protection

To provide proper ESD protection for the inner PCB, it is mandatory to place fast-responding TVS protection diodes at specific locations. General-purpose TVS diodes can be used depending on the position to be protected (e.g. where the signal frequency is low and therefore device capaci-

tance does not matter). Dedicated low-capacitance TVS diodes must be used for high-speed data lines to avoid any impact on signal integrity. The higher the data rate, the more the device capacitance matters. Figure 32 shows the available ESD protection devices for various interfaces in mobile devices.

### ESD protection diodes for General Purpose Interfaces

Product	Application	$V_{RWM}$ [V]	ESD <sup>1)</sup> [kV]	$V_{CL}$ <sup>2)</sup> [ $V_{CL}$ ] @ [A]	$R_{dyn}$ <sup>3)</sup> [ $\Omega$ ]	$I_{PP}$ <sup>4)</sup> [A]	$V_{CL}$ <sup>5)</sup> [V]	$C_T$ <sup>6)</sup> [pF]	Protected Lines	Package
ESD202-B1-W01005	Gen. purpose	±5.5	±16	±13 @ ±16 ±15 @ ±16	0.2	3	12	6.5	1	WLL-2-2
<a href="#">ESD230-B1-W0201</a>	Gen. purpose	±5.5	±15	±13 @ ±16	0.22	3	14	7	1	WLL-2-1
<a href="#">ESD231-B1-W0201</a>	Gen. purpose	±5.5	±30	±12 @ ±16 ±16 @ ±30	0.3	2 9	8 10	3.5	1	WLL-2-1
<a href="#">ESD233-B1-W0201</a>	Gen. purpose	±5.5	±20	±13 @ ±16	0.2	3	12.5	33	1	WLL-2-1
<a href="#">ESD234-B1-W0201</a>	Gen. purpose	±5.5	±20	±13 @ ±16	0.2	3	12.5	56	1	WLL-2-1
<a href="#">ESD237-B1-W0201</a>	Gen. purpose	±8.0	±16	±13 @ ±16 ±17 @ ±30	0.21	3	12	7	1	WLL-2-1
<a href="#">ESD239-B1-W0201</a>	Gen. purpose	±22.0	±16	±27 @ ±16	0.27	3		3.2	1	WLL-2-3
<a href="#">ESD241-B1-W0201</a> <a href="#">ESD242-B1-W01005</a>	Gen. purpose	±3.3	±15	±6 @ ±16	0.1	4		6.5 6	1	WLL-2-3 WLL-2-2
<a href="#">ESD245-B1-W0201</a> <a href="#">ESD246-B1-W01005</a>	Gen. purpose	±5.5	±15	±7.5 @ ±16	0.1	5		5.8 5.5	1	WLL-2-3 WLL-2-2
<a href="#">ESD249-B1-W0201</a>	Gen. purpose	±18.0	±16	±23 @ ±16	0.27	3		4.2	1	WLL-2-3

1) Electrostatic discharge as per IEC61000-4-2, contact discharge

2) TLP clamping voltage for 100 ns pulse length

3) Dynamic resistance (ON-resistance) evaluated with TLP measurement (100 ns pulse length)

4) Maximum peak pulse current according to IEC61000-4-5 (8/20  $\mu$ s)

5) Clamping voltage at  $I_{PP,max}$  according to IEC61000-4-5 (8/20  $\mu$ s)

6) Typical capacitance at 1 MHz (unless specified), 0 V, I/O vs. GND

7) Please visit <https://www.infineon.com/esd> for alternative devices

### Low capacitance ESD protection diodes for high speed and RF interfaces

Product	Application	$V_{RWM}$ [V]	ESD <sup>1)</sup> [kV]	$V_{CL}$ <sup>2)</sup> [ $V_{CL}$ ] @ [A]	$R_{dyn}$ <sup>3)</sup> [ $\Omega$ ]	$I_{PP}$ <sup>4)</sup> [A]	$V_{CL}$ <sup>5)</sup> [V]	$C_T$ <sup>6)</sup> [pF]	Protected Lines	Package
<a href="#">ESD106-B1-W0201</a>	Medium power RF	±5.5	±12	±16 @ ±8 ±25 @ ±16	1.1	1.5	10.0	0.13	1	WLL-2-3
ESD111-B1-W0201	High linearity requirement	±5.5	±11	±19 @ ±8 ±30 @ ±16	1.29	2.0	11.0	0.12	1	WLL-2-3
ESD150-B1-W0201	USB 4, USB 3.x SuperSpeed	±3.3	±12	±4.2 @ ±8 ±5.4 @ ±16	0.16	3.0	3.8	0.16	1	WLL-2-3
<a href="#">ESD119-B1-W01005</a> <a href="#">ESD130-B1-W0201</a>	Med. P <sub>RF</sub> <a href="#">AN392</a>	±5.5	±25	±20 @ ±16 ±31 @ ±30	0.8	1.0 2.5	11 14	0.3	1	WLL-2-2 WLL-2-1
<a href="#">ESD128-B1-W0201</a> <a href="#">ESD129-B1-W01005</a>	NFC-RF <a href="#">AN244</a>	±18.0	±15	±32 @ 16	0.85	1.0	18.5	0.3 0.25	1	WLL-2-1 WLL-2-2
<a href="#">ESD131-B1-W0201</a> <a href="#">ESD133-B1-W01005</a>	High-Speed interfaces	±5.5	±20	±8.5 @ ±8 ±13 @ ±16	0.6 0.56	3.0	5.5	0.25 0.23	1	WLL-2-3 WLL-2-2
<a href="#">ESD144-B1-W0201</a>	NFC-RF	±18.0	±15	±13 @ ±16	0.6	2.0		0.25	1	WLL-2-3
<a href="#">ESD5V5U5ULC</a>	USB2.0-HS $V_{CC}$	+5.5	±25	8.9 @ 16 11.5 @ 30	0.2	6.0	10.0	0.45	4	SC74

1) Electrostatic discharge as per IEC61000-4-2, contact discharge

2) TLP clamping voltage for 100 ns pulse length

3) Dynamic resistance (ON-resistance) evaluated with TLP measurement (100 ns pulse length)

4) Maximum peak pulse current according to IEC61000-4-5 (8/20  $\mu$ s)

5) Clamping voltage at  $I_{PP,max}$  according to IEC61000-4-5 (8/20  $\mu$ s)

6) Typical capacitance at 1 MHz (unless specified), 0 V, I/O vs. GND

7) Please visit <https://www.infineon.com/esd> for alternative devices



## 8 Support material

More detailed information on all available Infineon devices for mobile applications



[www.infineon.com/mobiledevices](http://www.infineon.com/mobiledevices)

### Datasheets/Application notes/Technical documents

Visit the product's internet pages and find them under "Document".

In this application guide, you can directly access the product pages, and the application notes from the product recommendation table.



[www.infineon.com/rf](http://www.infineon.com/rf)

### Component libraries for RF devices

To download the device simulation files such as S-parameters or ADS/MWO design kit, visit the product's Internet pages and find them under "Simulation".













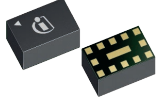
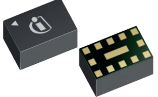
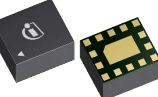

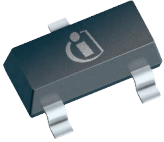

[www.infineon.com/rfcomponentlibraries](http://www.infineon.com/rfcomponentlibraries)









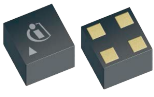
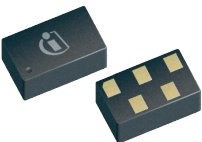
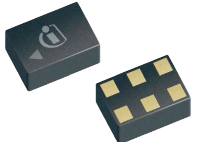
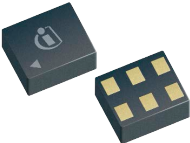
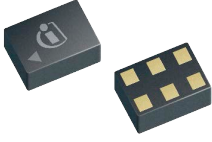
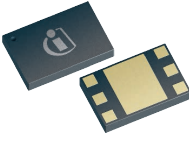
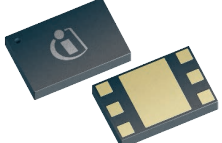

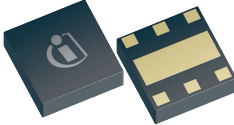
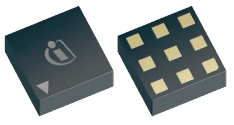

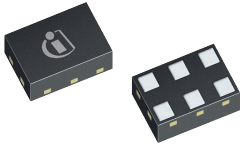
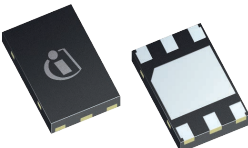
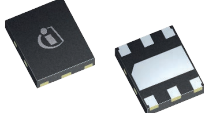
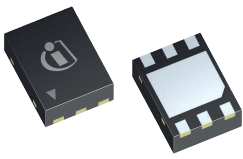
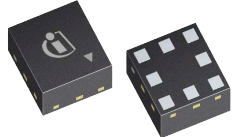
## 9 Abbreviations

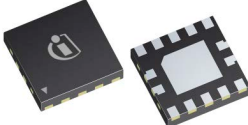
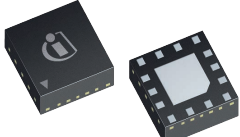
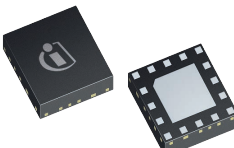
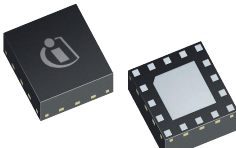
Abbreviations	Terms
ATSLP	Advanced Thin Small Leadless Package
ASM	Antenna Switch Module
BDS	Beidou Navigation System
CA	Carrier Aggregation
CDMA	Code Division Multiple Access
CMOS	Complementary Metal-Oxide-Semiconductor
CSP	Chip Scale Package
DC	Direct Current
DDA	Dual Diversity Antenna
DL	Downlink
DLCA	Downlink Carrier Aggregation
DPDT	Double Pole Double Throw
DP	Display Port
DSSS	Direct Sequence Spread Spectrum
EM	Electro-Magnetic
EMI	Electromagnetic Interference
ENDC	E-UTRAN New Radio – Dual Connectivity
ESD	Electro-Static Discharge
FDD	Frequency-Division Duplexing
FHSS	Frequency-Hopping Spread Spectrum
FM	Frequency Modulation
GLONASS	Global Orbiting Navigation Satellite System
GNSS	Global Navigation Satellite System
GPIO	General Purpose Input/Output
GPS	Global Positioning System
IC	Integrated circuit
IL	Insertion Loss
IMD	Intermodulation Distortion
IRNSS	Indian Regional Navigation Satellite System
ISM	Industrial, Science and Medicine
LAA	License Assisted Access
LNA	Low Noise Amplifier
LMM	LNA multiplexer modules
LTE	Long-Term Evolution
LTE-A	LTE-Advanced
LTE-U	Unlicensed Long-Term Evolution
MIPI	Mobile Industry Processor Interface
MIPI RFFE	Mobile Industry Processor Interface for RF Frontend Devices
MMIC	Monolithic Microwave Integrated Circuit

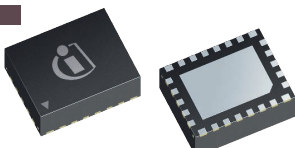
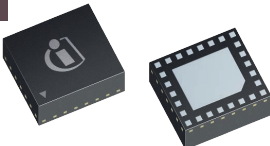
Abbreviations	Terms
MIMO	Multiple Input Multiple Output
MU	Multi-User
NF	Noise Figure
NFC	Near-Field Communication
OFDM	Orthogonal Frequency Division Multiplexing
PA	Power Amplifier
PCB	Printed Circuit Board
PIFA	Planar Inverted F antenna
PIN-Diode	Positive-Intrinsic-Negative diode
QAM	Quadrature Amplitude Modulation
QZSS	Quasi-Zenith Satellite System
RF	Radio Frequency
RF FE	RF Front-End
RoHS	Restriction of Hazardous Substances
RX	Receiver
SAW	Surface Acoustic Wave
SD	Secure Digital Card
SDARS	Satellite Digital Audio Radio Service
SiGe:C	Silicon Germanium Carbon
SPxT	Single Pole x Throw
SRS	Sounding Reference Signal
TDD	Time-division duplexing
TD-LTE	Time Division Long-Term Evolution
ToE	Time of Flight
TRP	Total Radiated Power
TSNP	Thin Small Non Leaded Package
TSLP	Thin Small Leaded Package
TVS	Transient Voltage Suppression
TX	Transmitter
UL	Uplink
ULCA	Uplink Carrier Aggregation
USB	Universal Serial Bus
UWB	Ultra Wide Band
VoIP	Voice over IP
W-CDMA	Wideband-Code Division Multiple Access
WLAN	Wireless Local Area Network
3GPP	3rd Generation Partnership Project
5G NR	5G New Radio

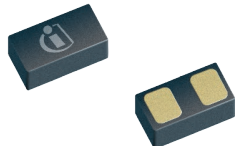
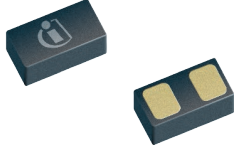
# 10 Package information

ATSLP-12-1 (-)		ATSLP-12-4 (-)		ATSLP-14 (-)		FWLP-6-1 (-)	
13	1.9 × 1.1 × 0.65	13	1.9 × 1.1 × 0.65	15	1.9 × 1.5 × 0.65	6	0.778 × 0.528 × 0.34
 3:1		 3:1		 3:1		 8:1	
SC79 (-)		SOT23 (-)		SOT323 (SC-70)		SOT343 (SC-82)	
2	1.6 × 0.8 × 0.55	3	2.9 × 2.4 × 1.1	3	2.0 × 2.1 × 0.9	4	2.0 × 2.1 × 0.9
 5:1		 4:1		 4:1		 4:1	
TSFP-4 (-)		TSLP-2-1 (-)		TSLP-2-7 (-)		TSLP-2-17 (-)	
4	1.4 × 1.2 × 0.55	2	1.0 × 0.6 × 0.4	2	1.0 × 0.6 × 0.39	2	1.0 × 0.6 × 0.39
 5:1		 5:1		 5:1		 5:1	
TSLP-2-19 (-)		TSLP-2-20 (-)		TSLP-3-1 (-)		TSLP-3-9 (-)	
2	1.0 × 0.6 × 0.31	2	1.0 × 0.6 × 0.31	3	1.0 × 0.6 × 0.4	3	1.0 × 0.6 × 0.31
 5:1		 5:1		 5:1		 5:1	
TSLP-4-4 (-)		TSLP-4-11 (-)		TSLP-5-2 (-)		TSLP-6-2 (-)	
4	1.2 × 0.8 × 0.4	4	0.7 × 0.7 × 0.3	5	1.3 × 0.8 × 0.39	6	1.1 × 0.7 × 0.39
 5:1		 5:1		 5:1		 5:1	
TSLP-6-3 (-)		TSLP-6-4 (-)		TSLP-7-1 (-)		TSLP-7-4 (-)	
6	1.1 × 0.9 × 0.39	6	1.1 × 0.7 × 0.31	7	2.0 × 1.3 × 0.4	7	2.3 × 1.5 × 0.4
 5:1		 5:1		 3:1		 3:1	

TSLP-7-6 (-)		TSLP-9-3 (-)		TSLP-10-1 (-)		TSNP-6-2 (-)	
7	1.4 × 1.26 × 0.39	9	1.15 × 1.15 × 0.31	6	1.1 × 0.7 × 0.31	6	1.1 × 0.7 × 0.375
 5:1		 5:1		 5:1		 5:1	
TSNP-7-1 (-)		TSNP-7-6 (-)		TSNP-7-10 (-)		TSNP-8-1 (-)	
7	2.0 × 1.3 × 0.375	7	1.4 × 1.26 × 0.375	7	2.3 × 1.7 × 0.73	8	1.1 × 1.1 × 0.375
 5:1		 5:1		 4:1		 5:1	
TSNP-9-1 (-)		TSNP-10-1 (-)		TSNP-14-2 (-)		TSNP-14-3 (-)	
8	1.1 × 1.1 × 0.375	10	1.5 × 1.1 × 0.375	15	1.95 × 1.8 × 0.375	15	1.95 × 1.8 × 0.375
 5:1		 5:1		 4:1		 5:1	
16	2.3 × 2.3 × 0.38	17	2.3 × 2.3 × 0.73	21	2.3 × 2.3 × 0.73	27	3.4 × 2.6 × 0.73
 3:1		 3:1		 3:1		 3:1	
TSSLP-2-4 (-)		WLL-2-1 (-)		WLL-2-2 (-)		Package (JEITA-code)	
2	0.62 × 0.32 × 0.31	2	0.58 × 0.28 × 0.15	2	0.43 × 0.23 × 0.15	X	L x W x H
 7:1		 7:1		 7:1		 7:1	
 7:1		 10:1		 10:1		 PIN-Count  Scale 1:1 All dimensions in mm	

All products are available in green (RoHS compliant).

Footprints are recommendations only.

For detailed information please refer to our datasheets or [www.infineon.com/packages](http://www.infineon.com/packages).



# Where to buy

Infiniteon distribution partners and sales offices:

[www.infineon.com/WhereToBuy](http://www.infineon.com/WhereToBuy)

# Service hotline

Infiniteon offers its toll-free 0800/4001 service hotline as one central number, available 24/7 in English, Mandarin and German.

- > Germany ..... 0800 951 951 951 (German/English)
- > China, mainland ..... 4001 200 951 (Mandarin/English)
- > India ..... 000 800 4402 951 (English)
- > USA ..... 1-866 951 9519 (English/German)
- > Other countries ..... 00\* 800 951 951 951 (English/German)
- > Direct access ..... +49 89 234-0 (interconnection fee, German/English)

\* Please note: Some countries may require you to dial a code other than "00" to access this international number.  
Please visit [www.infineon.com/service](http://www.infineon.com/service) for your country!

[www.infineon.com](http://www.infineon.com)

Published by  
Infineon Technologies AG  
81726 Munich, Germany

© 2021 Infineon Technologies AG.  
All rights reserved.

### Please note!

This Document is for information purposes only and any information given herein shall in no event be regarded as a warranty, guarantee or description of any functionality, conditions and/or quality of our products or any suitability for a particular purpose. With regard to the technical specifications of our products, we kindly ask you to refer to the relevant product data sheets provided by us. Our customers and their technical departments are required to evaluate the suitability of our products for the intended application.

We reserve the right to change this document and/or the information given herein at any time.

### Additional information

For further information on technologies, our products, the application of our products, delivery terms and conditions and/or prices, please contact your nearest Infineon Technologies office ([www.infineon.com](http://www.infineon.com)).

### Warnings

Due to technical requirements, our products may contain dangerous substances. For information on the types in question, please contact your nearest Infineon Technologies office.

Except as otherwise explicitly approved by us in a written document signed by authorized representatives of Infineon Technologies, our products may not be used in any life-endangering applications, including but not limited to medical, nuclear, military, life-critical or any other applications where a failure of the product or any consequences of the use thereof can result in personal injury.