

The Avago Advantage



Applications Solutions

Avago Technologies Solutions for **Industrial Networking**



Your Imagination, Our Innovation
Sense • Illuminate • Connect

Avago Technologies Solutions for **Industrial Networking**

Avago Technologies provides solutions for industrial networking applications. Optocouplers are used to maintain data integrity, thereby eliminating group loop current and common mode noise. Avago Technologies offers customers value with multi-channel and bi-directional optocouplers, as well as a series of digital optocouplers that operate at both 3V and 5V. For longer runs, optical fiber-based solutions are ideal as the fiber can be run very close to EMI producing devices without compromising the data link. Industrial Ethernet protocols are becoming more widely used, including standards such as ProfiNet, Interbus, and EtherCat. It is likely that fiber optic based links and electrically isolated links using digital optocouplers will co-exist for some time, and Avago offers solutions for both choices.

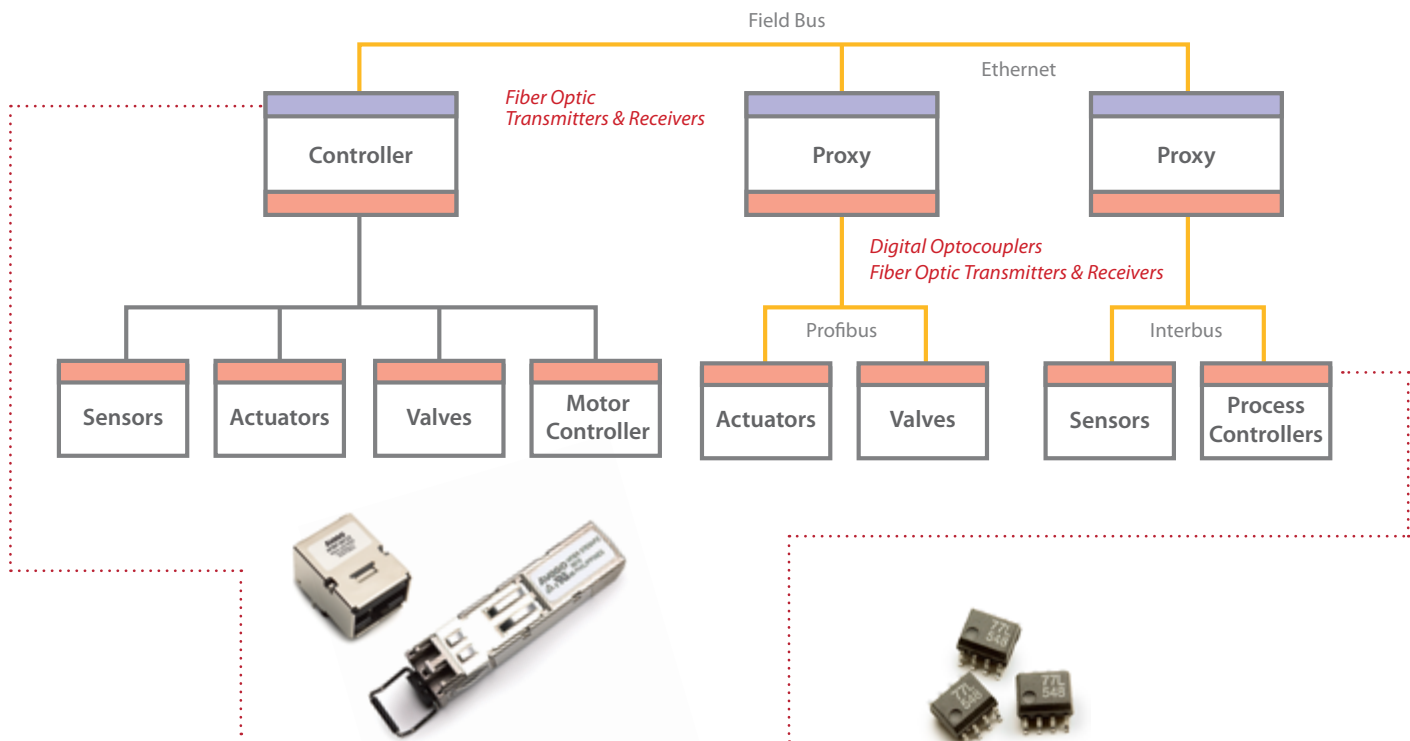

Fiber Optic Transmitters & Receivers

Avago industrial fiber transmitter and receivers operate reliably for data transmission over fiber in applications where the highest electrical isolation between the transmitter and receiver sides is needed. Fiber is not affected by electromagnetic radiation, making it suitable for use in surroundings with EMI present such as those found in industrial and factory environments.

Featured Products

- Optical Transmitter & Receiver for Industrial Applications with ST Port
- 10 MBd Optical Transmitter & Receiver for PROFIBUS applications
- 2 MBd Optical Transmitter & Receiver for INTERBUS-S applications
- 125 MBd SFP transceiver for Fast Ethernet network with DMI and SONET OC-3
- 650nm Transceiver with Versatile-Link connector for Fast Ethernet over POF
- 125 MBd Industrial Fast Ethernet Transceiver over Plastic Optical Fiber

Digital Optocouplers

Avago digital optocouplers provide low power, multi-channels and wide speed portfolio digital isolation without compromising on high voltage insulation and noise isolation performance.

Featured Products

- 10MBd Logic Gate Digital Optocouplers
- 5MBd Low Power Digital Optocouplers
- 1MBd Open-Collector Output Digital Optocouplers
- Multi-Channel Bi-Directional Digital Optocouplers
- 15/25MBd High Speed Digital CMOS Optocoupler

Your Imagination. Our Innovation



Avago Technologies is a leading designer, developer and global supplier of a broad range of analog, mixed signal and optoelectronics components and subsystems with a focus in III-V compound semiconductor design and processing. Backed by an extensive portfolio of intellectual property, Avago products serve three primary target markets: wireless communications, wired infrastructure, and industrial and other. Avago has a global employee presence and heritage of technical innovation dating back 50 years to its Hewlett-Packard roots.

Avago products serve three diverse end markets

Wireless Communications serving the smartphone/handset and Base Station infrastructure markets with leading-edge products that include:

- Power Amplifiers
- Front End Modules
- Film Bulk Acoustic Resonator (FBAR) Filters
- GPS/GLONASS LNAs
- Optical Finger Navigation
- LED Backlighting, Screen Illumination
- Ambient Light and Proximity Sensors

Wired Infrastructure for switches/routers, data centers, supercomputers and storage/servers with products that include:

- 168Gb Parallel Optic Arrays
- 28Gb SerDes ASICs in 28nm
- Storage Fibre Channel Transceivers
- QSFP+/SFP+ Ethernet Transceivers

Industrial and Other for alternative energy power generation, electronic sign and signals, automated manufacturing, automotive lighting, GPS/GLONASS navigation, motor inverter system, battery charging and management, infotainment systems and vehicle safety systems with products that include:

- Inverters
- Isolation and Digital Optocouplers
- Motion Control Optical & Magnetic Encoders
- Polymer Optical Fiber
- Indicator and Display LEDs



Contact us for your design needs at: www.avagotech.com

Avago, Avago Technologies, and the A logo are trademarks of Avago Technologies in the United States and other countries. Data subject to change. Copyright © 2013 Avago Technologies AV00-0204EN 09/23/13